

# ACTINIDE RESEARCH QUARTERLY

Ac Th Pa U Np Pu Am Cm Bk Cf Es Fm Md No Lr

First Quarter 2023

## CALCULATING CRITICALITY

Improving Performance  
in Plutonium Aqueous  
Chloride Operations



## Foreword

Fissile materials such as plutonium require a finely calibrated approach for safe handling. In the aqueous chloride operations in PF-4 (Plutonium Facility), scientists have identified several parameters that inaccurately estimate the neutron flux in these vital operations. On p2 we describe the experimental efforts supported by machine learning designs undertaken in 2021 to improve these calculations and prepare a benchmark sensitive to chlorine-35 ( $n,\gamma$ ) for the solution applications.

Criticality calculations are typically performed using the Monte Carlo method, a technique invented at Los Alamos in the 1940s for the purpose of predicting neutron diffusion in the hydrogen bomb. This method has had an enormous impact on innumerable disciplines both within and outside of science and technology—including economics, finance, transport, health, manufacturing, and virtually every profession that must measure risks. On p35 we present an account of the fascinating history of how the idea was conceived and realized with early computers.

Americium-241 is an important isotope for industry, yet until recently the US was dependent on foreign sources for its supply. Today, Los Alamos is proud to be the only manufacturing site of americium-241 in the US, having delivered its first shipment to customers in 2020. Recovery of americium from aged plutonium residues not only mitigated our dependence on foreign countries for sensitive materials but also reduced the waste disposal footprint, transforming a radioactive contaminant into a valuable commercial and research product (p8).

In the face of accelerating climate change, most experts agree that the only way to achieve rapid decarbonization of the energy grid is to embrace nuclear power. Specifically, development of advanced nuclear reactors, which promise improved safety, reduced cost, and a smaller waste footprint compared with conventional light-water reactors. To develop and deploy this technology rapidly, the federal government is working with private industry, providing support in the form of funding and licensing. Recently, the Department of Energy Advanced Research Projects Agency—Energy (DOE ARPA-E) has launched a suite of funding programs with a total of \$165 million to support advanced reactors. Two of these programs are highlighted in our article on p28.

— Owen Summerscales, Editor

**About the cover:** An artist's impression of neutron diffusion in an aqueous chloride solution of fissile plutonium. Researchers at the Plutonium Facility at Los Alamos National Laboratory have recently examined aqueous chloride operations for potential improvements to criticality models and have diagnosed several gaps between assumptions made for calculations and real-world experimental conditions. Read more about this story on p2.

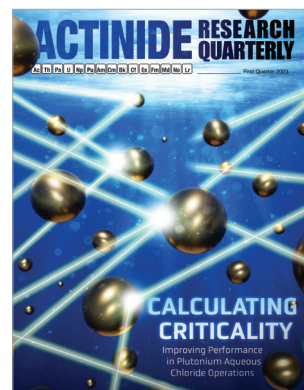

# Contents

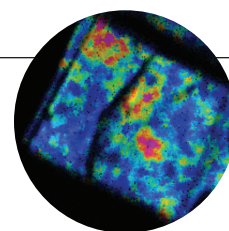

NUCLEAR SCIENCE

## 2 Calculating Criticality

NUCLEAR SCIENCE

## 28 DOE Funding for Advanced Nuclear Reactors

ACTINIDE ISOTOPES

## 8 United States of Americium

ACTINIDE THEORY

## 35 Hitting the Jackpot The Birth of the Monte Carlo Method

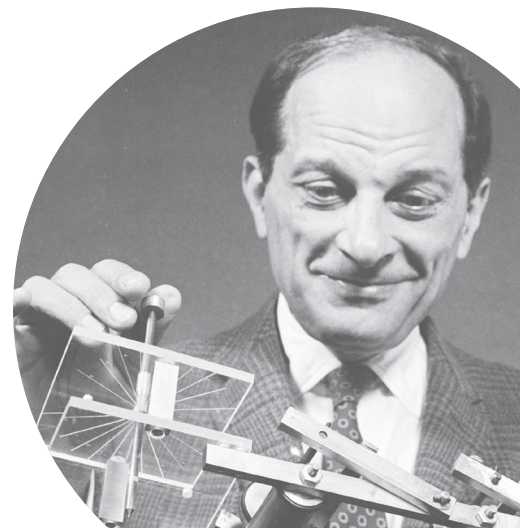

# Calculating Criticality

Since its foundation in 1943, Los Alamos has been designing experiments and crunching numbers to determine nuclear criticality parameters. At the time, it was blazing a trail into the terra incognita of nuclear science, a brand-new discipline that opened doors to both nuclear power and powerful weapons. Today, the Laboratory is still hard at work improving its knowledge of critical and sub-critical systems and collaborates with national and international partners to improve the safety and efficiency of nuclear systems by combining modern data science techniques with advanced experimental capabilities.

Criticality safety is a paramount consideration in the handling of fissile and fissionable materials such as plutonium-239. Uncontrolled nuclear chain reactions can result in dangerous bursts of high energy radiation and when these reactions are triggered accidentally, injuries or even fatalities may result. The Los Alamos report *A Review of Criticality Accidents* (McLaughlin et al. 2000) details 60 criticality accidents from 1944 to 1999 that caused 21 deaths globally (see *Actinide Research Quarterly*, 2022, First Quarter, for more information on the Demon Core criticality accidents during the Manhattan Project). Of these 60 incidents, 22 occurred in process environments outside nuclear reactor cores or experimental assemblies, 21 of which occurred with solutions, and 38 in small experimental reactors and other test assemblies. The discipline of criticality safety has consequently been shaped by these accidents and is now based on prevention with careful system analysis and prediction.

Researchers at Los Alamos have recently identified potential improvements to the criticality limits used in the aqueous chloride (AQCL) operations at the Plutonium Facility (PF-4), which are part of the plutonium recovery efforts. These improvements should reduce both worker radiation dose and operational costs, and could also increase batch processing rates in fundamental work tied to pit production. To meet mission requirements to produce a minimum of 30 pits per year by 2026, it is essential that all the manufacturing steps involving plutonium are examined in detail and streamlined while maintaining criticality safety standards.

## How criticality parameters are developed

Nuclear chain reactions are affected by a range of parameters summarized by the acronym MAGIC MERV (mass, absorption, geometry, interaction, concentration, moderation, enrichment, reflection, and volume); temperature is also a factor. These parameters are carefully controlled and used as inputs in computer models. Calculations are performed using advanced neutron transport codes, such as the Monte Carlo N-Particle® (MCNP®) code developed at Los Alamos (read about the history of the Monte Carlo method at Los Alamos on p35). These models, which approximate the properties of a nuclear system or operation, are combined with credible unfavorable conditions to give a set of operational limits that govern the bounds of safe work with fissile materials. This includes mass limits, volume restrictions, and handling practices which are incorporated into operator training.

Although fissile solids have been successfully modeled with the above method, aqueous fissile solutions pose a different and more complex challenge that has not yet been adequately solved. Even simple properties such as density are not well known for fissile solutions relevant to nuclear energy and security. Furthermore, chemical solutions are inherently variable in ways that counterintuitively affect criticality risk—these factors include container geometry,\* concentration, chemical speciation/





**Figure 1.** José Benito Vigil IV and Nathan Robbins (PT-1) working at TA-55 using a metal chlorination process. *Courtesy: Nathaniel Madlem.*



reactivity, and light element neutron moderators (which slow down fast neutrons and make them more effective in the fission chain reaction). \*Thin slab tanks, small diameter pencil tanks, annular tanks, and other designs have been used for criticality safety for solutions.

At present, limits at PF-4 for aqueous chloride processing are calculated without accounting for chlorine, although chlorine-35 is known by differential measurements to have high thermal neutron capture. The aqueous mixture density is simply extrapolated from the density of solid  $\alpha$ -plutonium ( $19.8 \text{ g/cm}^3$ ; for comparison, the density of water is defined as  $1 \text{ g/cm}^3$ ) and includes only plutonium and water. These assumptions represent an overly conservative approach, currently allowing for a maximum of 520 g of plutonium in solution. Furthermore, criticality is attenuated by the presence of chlorine-35 in hydrochloric acid and metal salts, which are physically required for the plutonium to be dissolved in solution. In the available nuclear data, there are very few experimental benchmarks used for code validation that are sensitive to chlorine-35 ( $n, \gamma$ ), and of these few benchmarks, the sensitivity is much lower than the application.

### Improving the models

Researchers at Los Alamos have recently asked themselves, *how can we improve the accuracy of our solution models?* To answer this question, they designed a series of experiments with the aid of machine learning protocols that characterize key features of aqueous plutonium chloride solutions. The experiments had two main objectives: (i) benchmarking neutron absorption from chlorine, and (ii) determining plutonium solution densities.

The research team investigated chlorine neutron absorption in the Chlorine Worth Study (CWS), which included critical experiments using a fissile fuel and chlorine-containing material. These experiments were designed using machine learning methods to match the chlorine absorption sensitivities for AQCL operations at PF-4. The CWS experiments took place at the National Criticality Experiments Research Center (NCERC), owned and operated by Los Alamos at the Nevada

Nuclear Security Site (NNSS), over three weeks in December 2021. Experiments were performed by a team including co-leads Theresa Cutler (NEN-2) and Travis Grove (NEN-2), along with Kelsey Amundson (NEN-2), Jesson Hutchinson (NEN-2), Noah Kleedtke (XCP-5), and Nicholas Wynne (NEN-2). The concluding task of integrating the data to generate a final benchmark is underway and is intended to be completed by spring 2023.

Plutonium solution characteristics were investigated for a ternary mixture of plutonium chloride, hydrochloric acid, and water ( $\text{PuCl}_x/\text{HCl}/\text{H}_2\text{O}$ ) by measuring water activity and solution density. This work is ongoing and aims to incorporate experimental density data into a function density law using the semi-empirical Pitzer equation, which then would be implemented in the MCNP model. The team who performed this work include the following: Kelly Aldrich (C-AAC) and Dung Vu (C-AAC) as project lead and co-lead; Laura Worl\* (DPO-MRR) as funding manager; Kimberly Bonilla (C-AAC) and Justin Cross (C-AAC) as contributing researchers; Steve Willson (C-AAC), Jennifer Alwin\* (XCP-7), Riley Bulso\* (NCS), Alicia Salazar Crockett\* (NCS), Theresa Cutler\* (NEN-2), David Kimball\* (AMPP-4), and James Bunsen\* (AMPP-4) in advisory roles. \*Contributed to both CWS and solution density experiments.

## Effective neutron multiplication factor

In nuclear reactor theory, the neutron multiplication factor  $k$  is a key ratio that represents the average number of neutrons from one fission that causes another fission. If  $k$  is less than 1, the system is subcritical and cannot sustain a chain reaction; the neutron population will exponentially decay. If  $k = 1$ , the reaction is critical, and the neutron population will remain constant. Finally, if  $k$  is greater than 1, the reaction is supercritical, and the neutron population will grow exponentially.

For criticality safety,  $k$  must always be less than 1 when handling fissile materials. There is an additional margin of around 0.05 below this cutoff for all normal and credible abnormal process conditions, but the exact figure varies based on the circumstances. MCNP codes produce the effective neutron multiplication factor  $k_{eff}$  as an output eigenvalue, which informs scientists of the criticality risk. This parameter is defined as the ratio of the number of free neutrons in a generation to the number of neutrons in the previous generation, accounting for all fission contributions and losses due to scattering, absorption, and leakage.

$$k_{eff} = \frac{\text{neutron production rate}}{\text{neutron loss rate}}$$

## Chlorine-35: Neutron sink

Aqueous chloride operations involve significant quantities of chlorine, largely in the form of hydrochloric acid, chloride salts, and plutonium chloride in aqueous solution. Previous differential experiments have characterized a large thermal neutron cross section for the stable isotope chlorine-35 (76% natural abundance) in an  $(n,\gamma)$  reaction, giving chlorine-36 (half-life  $3 \times 10^5$  years) as the product along with gamma radiation.<sup>†</sup>

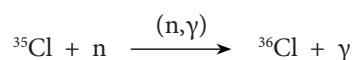

<sup>†</sup> Historically, large amounts of chlorine-36 were produced by neutron irradiation of seawater (containing sodium chloride) in the Pacific during atmospheric testing of nuclear weapons by the US, UK, and France in the 1940s–1990s.





### Nuclear data: Benchmarking and the ICSBEP

Benchmarks underpin the science of criticality: they comprise complete collections of experimental data, along with fully documented details and complete uncertainty analysis of the experiments that produced them. Benchmarks are used to validate codes such as MCNP and also serve to adjust nuclear data. Los Alamos has designed and executed critical and subcritical benchmarks since 1945 and continues this work today at NCERC. In 1992, in order to standardize this nuclear data, the US Department of Energy (DOE) established what would become the International Criticality Safety Benchmark Evaluation Project (ICSBEP) under the intergovernmental Nuclear Energy Agency (NEA), allowing criticality safety analysts to validate calculation tools and cross-section libraries.

The ICSBEP handbook contains over 5,000 critical and subcritical configurations, which all undergo extensive peer review before publication. Benchmarks are also used by the Los Alamos Nuclear Criticality Safety Division (NCSD) for validation of their codes, which ensure that fissile material operations can be performed without risk of criticality. The intent is for the current CWS experiments to be evaluated and submitted to the ICSBEP as a recognized criticality safety benchmark for chlorine-35. This is a significant undertaking: a benchmark report of this type will often weigh in at around 500 pages and undergo a much more thorough peer review process than a typical academic publication.

The cross section of the chlorine-35 ( $n,\gamma$ ) reaction is known from differential experiments, however the data still needs to be validated in the thermal neutron regime using integral experiments. In other words, researchers have the neutron absorption data for chlorine-35 in isolation, but how it behaves in a complex fissile environment needs to be investigated. These types of integral experiments, such as CWS, measure neutron period and use this data to calculate  $k_{eff}$ .

Coincidentally, work is underway by a different team at the Los Alamos Neutron Science Center (LANSCE) to calculate the cross section for the chlorine-35 ( $n,p$ ) reaction in a fast neutron energy regime. This effort is being supported by TerraPower as part of their work to develop a molten chloride fast reactor. They hope that by obtaining high-quality measurements of chlorine-35 and chlorine-37 cross sections and re-evaluating the corresponding nuclear data libraries, they can reduce regulatory uncertainty for these new types of advanced reactors (see article on p28).



**Figure 2.** The Chlorine Worth Study team at NCERC. *Left to right:* Gabrielle Ambrosio, Leah Berman, Theresa Cutler, Jesson Hutchinson, Christopher Lopez, David Kimball.

Theresa Cutler (*left*) assists as Leah Berman (*right*) loads plutonium plates for experiment. *Inset, bottom right:* ZPPR plates in a 5-by-4 array.

## Part 1: Chlorine Worth Study

### Design considerations

For the design of these experiments, researchers had to make several important choices regarding fuel type, type of chlorine-containing material, concentration range to match, and type of additional moderating materials. Aqueous solutions containing fissile materials are not considered safe for experiments at NCERC, therefore the solution environment had to be emulated using solid materials that contained both chlorine and hydrogen atoms (the latter being important as a neutron moderator that is present in water). The experiments were designed such that the chlorine absorption sensitivities in the experiment model matched the solution application in PF-4.

Multiple fuel types were considered, including both high-enriched uranium as well as plutonium, but ultimately plutonium was chosen in the form of the Plutonium-Aluminum No-Nickel (PANN) Zero Power Physics Reactor (ZPPR) plates, which have been used in several recently published ICSBEP benchmarks. These are steel-clad weapons-grade plutonium plates roughly  $2 \times 3 \times 0.125$  in with a mass of approximately 100 g plutonium-239 per plate and used in a 5-by-4 array (i.e., 20 plates, see Fig. 2).

When examining possible chlorine-containing moderating materials for use in the CWS experiments, the team used several metrics, including chlorine content, safety, neutron moderation (i.e., how much the material will mimic chlorine in solution), scattering data availability, lack of competing reactions, and other practical considerations such as low cost and room temperature solid state. Organic materials examined were polyvinyl chloride (PVC), chlorinated polyvinyl chloride (CPVC), dechlorane plus (DCP), and tris(2-chloroethyl) phosphate (TCEP). Inorganic materials examined were potassium chloride, sodium chloride, magnesium chloride, and magnesium chloride hexahydrate. While all the listed materials have high chlorine content, the organic materials were of more interest than the inorganic materials, mainly due to the competing reactions metric. Of the organic materials, TCEP is a carcinogen and DCP has environmental impact issues. Therefore, the chlorine-containing materials that were chosen for use in the CWS experiments were PVC and CPVC.





**Figure 3.** Anniversary challenge coin issued in 2021 celebrating 10 years of operations at NCERC. Over the past decade, NCERC has executed more than 50 experiments using its unique critical assemblies.



High-density polyethylene (HDPE) was chosen as reflector and additional moderating material. This was needed to thermalize (slow down) the neutrons without capturing them, as chlorine-containing materials absorb too many neutrons to thermalize the system on their own. Thermal neutrons are needed to simulate the type of environment found in AQCL operations (“thermal” refers not to a high temperature but that the neutrons are in thermal equilibrium with the medium they are interacting with, i.e., the reactor’s fuel, moderator, and structure, which is much lower energy than the fast neutrons initially produced by fission).

Three different plutonium concentration ranges were chosen that cover most of the practical possibilities and where the sensitivities are similar. One representative model per range was chosen: 20–90, 200–400, and 500–600 g/L, corresponding to 30, 300, and 600 g/L models, respectively. To recreate these three different plutonium concentrations, three different material geometries were designed. For this, machine learning techniques developed during the ARCHIMEDES Laboratory Directed Research and Development (LDRD) Reserve project were used in combination with MCNP and other codes to calculate the partial  $c_k$  similarity coefficient for chlorine-35 ( $n,\gamma$ ) reactions of the proposed designs compared to the application models ( $c_k$  and partial  $c_k$  are similarity coefficients that use model sensitivities for nuclear data and uncertainties associated with that data).

The intrinsic heat generated from the plutonium fuel plates was also considered in the design. The team modeled this aspect with predictive calculations using the COMSOL® Multiphysics software, which showed that leaving heat dissipation to air convection alone would increase the steady-state temperatures in the experiment to well over 75 °C. Therefore, heat conduction was achieved using interlocking aluminum frames that conducted heat to two primary heat sinks—the bottom stack conducted heat to the moveable platen, and the top stack transferred heat to the top plate. With this amendment in the design, the model indicated that the maximum steady-state temperature would be much safer at approximately 33 °C, compared to greater than 75 °C in the original design.

### Chlorine Worth Study: Final design

The three final design configurations all featured approximately three inches of HDPE as an outer reflector and a series of layers which each include 20 ZPPR plates in a 5-by-4 array, aluminum trays and frames to support each unit of the configuration as well as provide heat transfer out to the top plate and platen, internal absorbers (PVC/CPVC), and an internal moderator (HDPE). Twelve resistance temperature detector (RTD) inputs were slotted into the aluminum trays to provide temperature monitoring.

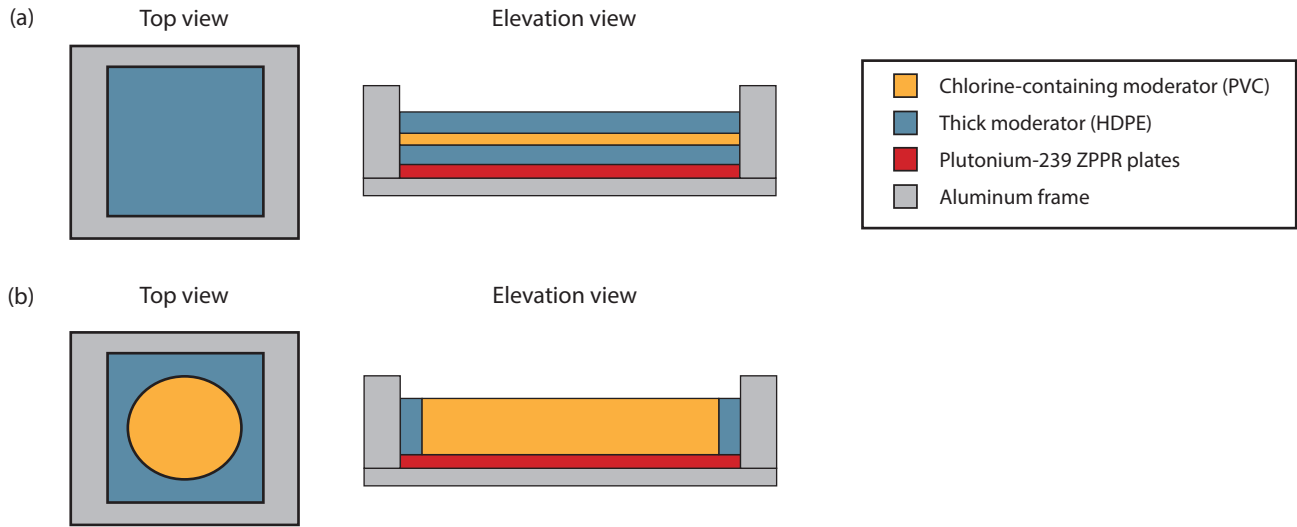

**Figure 4.** Final unit designs for (a) configuration 1 and (b) configurations 2 and 3 (chlorine-containing moderator is PVC in configuration 2, CPVC in configuration 3). Not to scale.

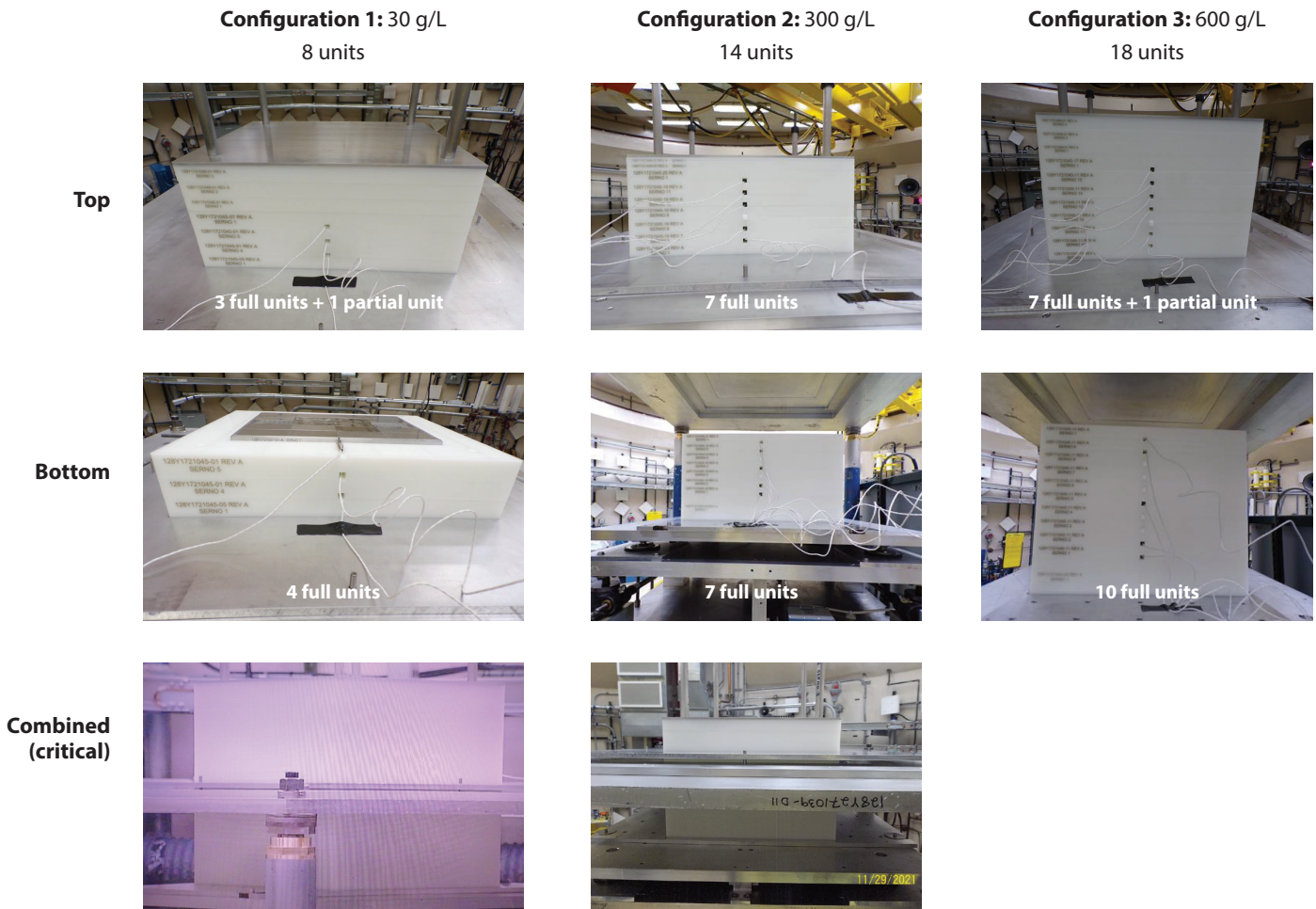

**Figure 5.** In-situ images of the two halves of the final experimental configurations and the combined critical configurations for all three experiments at 30, 300, and 600 g Pu/L.





**Figure 6.** CWS team members at the NCERC critical assembly control center.



The three configurations, corresponding to 30, 300, and 600 g/L applications, are shown in Figs. 4 and 5. Configuration 1 contains PVC as the chlorine-containing material sandwiched between two thicker layers of HDPE, all sitting on a layer of ZPPR plates. Configurations 2 and 3 share the same geometry, with a circular layer of chlorine-containing material (PVC in configuration 2, CPVC in configuration 3) surrounded by HDPE as an outer reflector, all on top of ZPPR plates. These configurations are assembled as two separate halves, split horizontally using the “1/M approach,” with each portion having less than three-quarters of the predicted critical mass. This point is called the handstack limit, which is when researchers transition from local to remote operations. Using the Planet assembly machine, the two parts of the critical configuration are brought together mechanically with remote control (Fig. 6).

The team performed the CWS experiments at NCERC over a three-week period in December 2021. During the second week, AQCL operations personnel attended, participating in the 1/M approach-to-critical process and loading fuel into the experimental configurations (Fig. 2). The group included a full range of workers from simulation experts, experimentalists, and engineers through to on-the-floor process operators who would directly benefit from increased limits. Involvement of these AMPP (Actinide Materials Processing & Power) employees was a unique aspect of the project—normally, the research would have been performed solely by a small core team at NCERC—and significantly contributed to the esprit de corps felt by the team for their mission-critical work.

The team is currently processing the data to produce a final benchmark, taking extraordinary effort to best understand the system and minimize overall uncertainty. Error margins associated with the critical configurations include uncertainties from many factors: material composition, physical dimensions, reactor period measurement, temperature effect, and nuclear data, among others. This painstaking

## Critical assembly machine: Planet

One of four critical assembly machines located at NCERC, Planet is a general-purpose vertical-lift assembly machine that was used in the CWS experiments. Critical experiments are conducted on Planet by remotely bringing two halves of a critical assembly together into a critical configuration using a hydraulic lift mechanism. Planet's simple design, which operates at essentially zero power (less than a watt), allows for a wide variety of experimental configurations, and measures subcritical neutron multiplication and critical reactor periods as a function of separation between experimental components. Planet uses gravity as a passive shutdown mechanism—it fails in an “open state.” This mechanism has been in wide use since the “demon core” criticality accidents at Los Alamos in the 1940s.

Currently located at NCERC (at the NNSS in Nevada), Planet was previously housed at TA-18 as part of the Los Alamos Critical Experiments Facility (LACEF). Following more than 20 years of operation during which it conducted 30 ICSBEP benchmarks, it was moved in 2008 as part of the de-inventory operations of LACEF and became fully functional again in 2011 (note: “de-inventory” is the process of removing fissionable material with the goal of eliminating the need for criticality safety control).

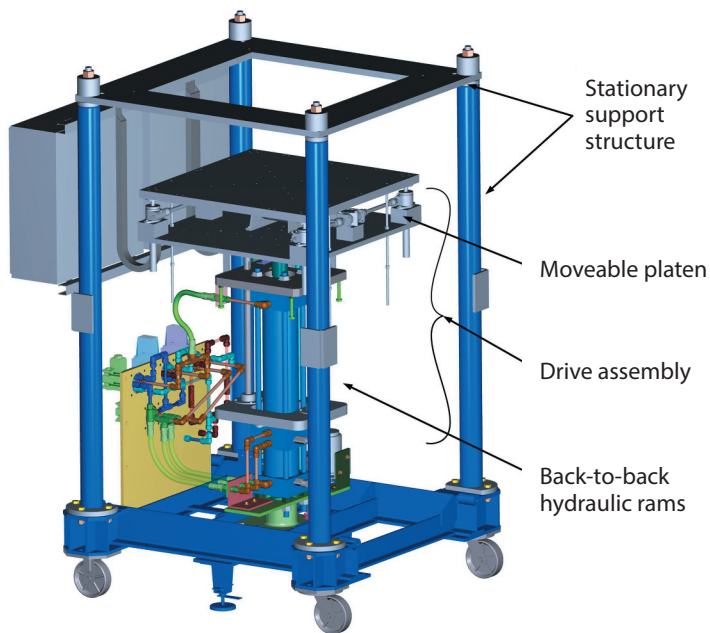

**Planet critical assembly machine without experimental setup.** This is a general purpose vertical assembly machine designed to accommodate experiments in which neutron multiplication is measured as a function of separation distance between experimental components. *Courtesy: Sanchez et al., Nuclear Science and Engineering, June 2021.*



**Planet loaded with CWS critical assembly.** Note the configuration is split into two pieces to keep the assembly from becoming critical while workers are in the room. The lower platen is raised remotely to lock in with the stationary upper stack to achieve criticality (see Figs. 5 and 6 on previous spread).



operation includes details down to sending samples of plastics used for detailed chemical analysis. Benchmarking will officially take place in the spring (2023) at the ICSBEP technical review group meeting in Paris, France. In addition to this benchmark evaluation, the data will be given to the Los Alamos NCSD to be used in future criticality safety evaluations to reassess fissile mass limits in PF-4 processes.

## ARCHIMEDES and EUCLID

In the last three years, two machine learning projects have been funded through the LDRD program at Los Alamos that aim to improve the nuclear data pipeline: ARCHIMEDES (Application Relevant Critical/Subcritical HEU/Pu-based Integral Measurements for Enhancing Data and Evaluating Sensitivities) in 2019–2020 and EUCLID (Experiments Underpinned by Computational Learning for Improvements in Nuclear Data) in 2021–2023. These projects use machine learning algorithms to first identify where compensating errors or gaps exist in nuclear data libraries and then use separate algorithms to design and optimize experiments to address these issues. Such improvements to nuclear data have potential applications in weapons, advanced reactors, and criticality safety.

ARCHIMEDES has four steps. First, the application is chosen, and a model of the process is generated using MCNP. Next, the radiation transport code is used to determine cross-section sensitivities both for the application model and for over 1,000 existing benchmark models. In the third step, these models are compared using the nuclear data covariance, and gaps are identified. Finally, machine learning algorithms are applied to optimize experiments, aiming to achieve a higher similarity coefficient to the application than existing ICSBEP benchmarks. These experiments can then be performed using the capabilities at NCERC. This overall process is how the CWS experiments described in this article were designed. In addition to designing improved experiments, these calculations should result in a better understanding of cross-section sensitivities for specific applications and help determine which existing criticality benchmarks are most relevant for such applications.

EUCLID expands on ARCHIMEDES and aims to reduce compensating errors in nuclear data libraries, lead to faster impact of integral experiments on nuclear data, and improve validation-experiment design with machine learning. This will create a valuable library of cross-section sensitivities as well as other computational tools which will be made available to data scientists. Error reduction will be achieved by using a suite of measurement types beyond  $k_{eff}$  for configurations that are optimally designed using machine learning. Advances in the ARCHIMEDES and EUCLID projects make it possible to design targeting experiments to answer specific application questions through nuclear data validation on a timescale much faster than previously achievable.

Team members: ARCHIMEDES: Jennifer Alwin\* (XCP-7), Rian Bahrn (GS-NNS), Travis Grove (NEN-2), Jesson Hutchinson\* (NEN-2), Joel Kulesza (XCP-3), Robert Little\* (XCP-3), Isaac Michaud\* (CCS-6), Alexander McSpaden (NEN-2), Michael Rising\* (XCP-3), Travis Smith\* (NEN-2), Nicholas Thompson\* (NEN-2). EUCLID: Brian Bell (XCP-5), Alexander Clark (XCP-3), Theresa Cutler (NEN-2), Michael Grosskopf (CCS-6), Wim Haeck (XCP-5), Michal Herman (T-2), Noah Kleedtke (XCP-5), Juliann Lamproe (NEN-2), Denise Neudecker (XCP-5), Scott Vander Wiel (CCS-6), Nicholas Wynne (NEN-2). \*Contributed to both ARCHIMEDES and EUCLID.

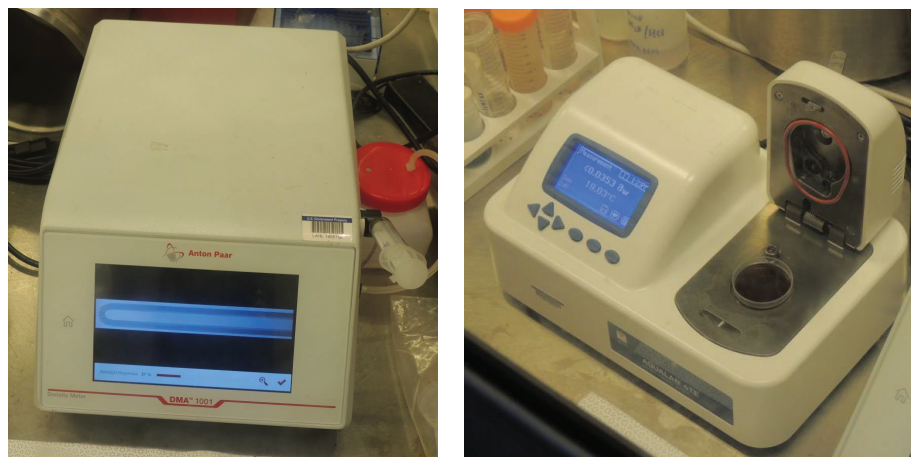

**Figure 7.** *Left:* Anton Paar DMA 1001 Precision density meter in a glovebox. The U-shaped sample chamber shown with plutonium chloride solution loaded using syringe. *Right:* AquaLab 4TE water activity meter with the sample compartment open, showing the sample chamber.

## Part 2: Determining solution density and water activity

The second thrust of the experimental work, performed by a separate team led by Kelly Aldrich (C-AAC), was to determine both the density and the water activity of aqueous plutonium/hydrochloric acid solutions. These characteristics were investigated using an Anton Paar 1001 density meter and an AquaLab 4TE water activity meter (Fig. 7), varying three parameters: (i) plutonium concentration, (ii) hydrochloric acid concentration, and (iii) plutonium oxidation state. Water activity, a value between 0 and 1, is defined as the partial vapor pressure of water in a solution divided by the standard state partial vapor pressure of water. It is a measure of the ideality of the solution behavior, which informs modeling parameters.

### Varying plutonium and hydrochloric acid concentration

Plutonium concentrations were examined in the range in which they typically demonstrate optimized moderation and have historically posed the highest risk for accidental criticality (30–100 g/L in detail; however, the model incorporates data in the range 0–260 g/L). Density measurements were taken at four different temperatures in the 20–40 °C range. The results showed that solution density increases significantly as plutonium content increases, as anticipated, and that it is inversely proportional to temperature.

For hydrochloric acid concentration, a set plutonium concentration of 60 g/L (Pu, 0.257 mol/kg) was chosen with varying concentrations of HCl (0.5–10 M range). The plutonium concentration chosen is a typical concentration for AQCL batches in PF-4 and happens to be in the optimally moderated portion of the criticality curve.

The density of plutonium solutions was found to increase with increasing HCl concentration, as would be expected. By subtracting the plutonium contribution from the data, researchers in C-AAC were interested to note a deviation from ideal behavior at higher concentrations, i.e., activity coefficient  $\neq 1$ . Unfortunately, they found that water activity measurements of the ternary plutonium solution showed a higher degree of error relative to density measurements. However, a statistically significant decrease in water activity, and consequently the activity coefficient, was observed at higher plutonium or HCl concentrations.



A successful working density law model was developed (an eight-parameter Pitzer model), which showed less than 2% error between the predicted and measured solution density values over the concentration ranges studied, with the average error even smaller. Future work under a wider range of experimental conditions is planned (examining low-acid and high-plutonium concentrations) that will establish bounding limits of the “simple solution” behavior of this ternary system to verify the binary plutonium chloride parameters.

### Plutonium oxidation states and effects on solution measurements

A known complication of aqueous plutonium chemistry is the presence of variable oxidation states. Researchers examined the solutions described above using UV-visible spectroscopy and found a mixture of Pu(III) and Pu(IV) (Fig. 8). In the plutonium concentration experiments, the two states were found in a 1:1 ratio, whereas in the hydrochloric acid concentration experiments, Pu(IV) was the major species (~75%). Using ascorbic acid as a reductant, density measurements were performed on solutions containing purely Pu(III) ions, and no significant differences were found in the mixed oxidation state solutions, which has been confirmed by more recent experiments. This means that a conservative estimate can be confidently used when crediting chlorine in the models using the experimentally derived density equation (i.e., 3:1 versus 4:1 chlorine-to-plutonium).

### MCNP calculations

Initial calculations were made using the MCNP code to test the effect of using a more realistic (i.e., lower) value for solution density and accounting for chlorine. The model was created with 600 g of plutonium-239 at 60 g/L concentration and infinitely reflected with water and HCl concentration varied. The crucial variable of solution density was initially calculated using the old density model (the volume and mass of alpha-plutonium are added to the volume and mass of the remaining liquid as water). The results then showed that the calculated  $k_{eff}$  was substantially reduced when a small amount of chlorine is accounted for in the model and an experimental solution density value is used.

The team concluded that even conservative chloride crediting—for example a 3:1 chlorine-to-plutonium stoichiometric ratio—could yield dramatic operational improvements while maintaining high confidence in subcriticality. By substituting the previously assumed solution density with a far more relevant experimental value, the models showed an approximate 10% decrease in  $k_{eff}$  at the optimal moderation concentration. This could lead to a change of almost 100 g in the allowable mass limit under which plutonium AQCL systems can safely remain subcritical.

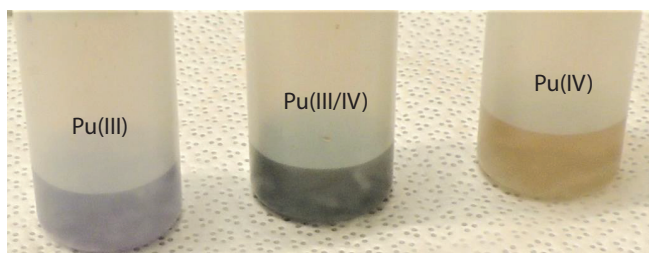

**Figure 8.** Plutonium can adopt several different oxidation states in solution. Here three permutations of oxidation state of plutonium chloride in aqueous hydrochloric acid solution are shown: Pu(III), Pu(III/IV), Pu(IV).

## Summary

Safely handling fissile materials is an essential requirement for completing a portion of the Los Alamos pit production mission and getting it right means having high-fidelity measurements and models. Los Alamos scientists have recently examined aqueous chloride operations in PF-4 for potential improvements to criticality models and have diagnosed several gaps between assumptions made for calculations and real-world experimental conditions. They found that the models use inaccurate estimates of solution densities and that they also disregard the influence of chlorine-35, which is a thermal neutron absorber that would be expected to reduce neutron flux under reaction conditions. For the latter, there were no appropriate benchmarks sensitive to chlorine-35 ( $n,\gamma$ ) for the application available in the nuclear data, therefore experimental work was initiated to obtain and benchmark this vital information.

Using designs originating from machine learning algorithms as part of the ARCHIMEDES and EUCLID projects, a set of criticality experiments was performed at NCERC in December 2021 to ascertain the precise influence of chlorine on the neutron multiplication factor,  $k_{eff}$ . A detailed benchmark evaluation is currently underway, which is intended to be submitted to the ICSBEP at the spring 2023 technical review group meeting and distributed to the Los Alamos Nuclear Criticality Safety Division to begin the process of reviewing the data in the context of PF-4 operations. This will include detailed modeling with new inputs using MCNP codes.

Supporting this work, an ongoing experimental effort has focused on determining accurate solution characteristics for ternary plutonium chloride/hydrochloric acid/water systems; in particular, solution density, water activity (i.e., solution ideality), and oxidation state/speciation. A broadly applicable density law has been designed for the system, which shows a high degree of accuracy and can be incorporated into the criticality models. Scoping studies have been performed to expand this work from plutonium chloride to oxalate (a species also present in AQCL operations, as described in the article on p16).

Combining the initial data indicates that by crediting for chlorine and using a more realistic value for solution density, significant increases in the operational limits of plutonium can be made while remaining safely subcritical. This could yield dramatic improvements for aqueous chloride operations at PF-4 and its current pit production mission.

## Acknowledgments

I would like to thank Theresa Cutler, Kelly Aldrich, Jesson Hutchinson, Nic Lewis, Maureen Lunn, and David Kimball for their help in the writing of this article, and Nathaniel Madlem, Theresa, and Kelly for providing photos. The TA-55 work was supported by the Plutonium Program Office (NA-191) under the Office of Production Modernization (NA-19), funded and managed by the NNSA for the DOE. NCERC is supported by the DOE Nuclear Criticality Safety Program, funded and managed by the NNSA for the DOE.

### Further reading:

1. T. Cutler, K. Amundson, J. Hutchinson, N. Kleedtke, N. Wynne, "The CWS Experiments – An Experimental Study of the Effects of Chlorine on Thermal Neutron Absorption," 2022 ANS Annual Meeting, Nuclear Criticality Safety Division Topical Meeting (NCSD 2022), Anaheim, CA (United States), 12-16 Jun. 2022, LA-UR-22-20549.
2. K.E. Aldrich, D.M. Vu, K.M. Bonilla, J.N. Cross, S.P. Willson, J. Alwin, D. Kimball, J. Bunsen, T. Cutler,



- 
- L. Worl, R. Bulso, A. Salazar-Crockett, "Experimental steps toward a density law for chlorine-crediting criticality models of aqueous plutonium solutions," 2022 ANS Annual Meeting, Nuclear Criticality Safety Division Topical Meeting (NCSD 2022), Anaheim, CA (United States), 12-16 Jun. 2022.
3. R. Sanchez, T. Cutler, J. Goda, T. Grove, D. Hayes, J. Hutchinson, G. McKenzie, A. McSpaden, W. Myers, R. Rico, J. Walker, R. Weldon, "A New Era of Nuclear Criticality Experiments: The First 10 Years of Planet Operations at NCERC," *Nucl. Sci. Eng.*, 2021, 195, S1-S16, S1.
4. J. Hutchinson, J. Alwin, R. Bahran, T. Grove, R. Little, I. Michaud, A. McSpaden, W. Myers, M. Rising, T. Smith, N. Thompson, D. Hayes, "Criticality testing of recent measurements at the National Criticality Experiments Research Center," 11<sup>th</sup> International Conference on Nuclear Criticality Safety, Sept. 15-20, 2019, Paris, France.
5. T.P. McLaughlin, S.P. Monahan, N.L. Pruvost, V.V. Frolov, B.G. Ryazanov, V.I. Sviridov, "A Review of Criticality Accidents," LA-13638, 2000.

# United States of Americium

You may not consider americium-241 to be a household name. However, it is the one actinide that is found in almost every household: as an isotope that produces ionizing radiation, it is an essential component of smoke detectors. There are dozens of other important uses for americium-241, yet its supply as a controlled material has been unreliable—subject to international markets and associated geopolitical turbulence due to the governmental nature of international nuclear production sites. The US has been reliant on these unreliable supply chains since 2004, however recent efforts have reestablished domestic production of americium-241, which resumed in 2017 after a 33-year hiatus. This milestone has proved to be a turning point in the critical area of isotopes, eliminating a vulnerability from our radioactive source supply chain and reducing our dependence on sensitive sources.

Today, Los Alamos is proud to be the only manufacturing site of americium-241 in the US, having delivered its first shipment to customers in 2020. As an unwanted impurity that grows into nuclear waste streams and stockpiles of plutonium, americium-241 increases the radiation dose of these aging materials and makes downstream processing a challenge. Removal of this contaminant reduces the radioactivity of these waste streams and transforms a highly radioactive waste constituent into a valuable industrial and research product—a true win-win for both scientists and taxpayers.

In this article, we will examine how Los Alamos has achieved this milestone and also cover the history of americium, from the curious announcement of its discovery on a children's radio show to its manifold uses that range from the commonplace to the celestial.

## Quiz kids: Americium history

Americium was first isolated and characterized by Glenn Seaborg, Leon (Tom) Morgan, Ralph James, and Albert Ghiorso (Fig. 2) in late 1944 following experimental work at UC Berkeley, Clinton Engineer Works, and the Hanford Site, and analytical work at the Metallurgical Laboratory of the University of Chicago. Using the same 60-inch cyclotron that was employed to synthesize plutonium (1940) and curium (1944), they bombarded plutonium-239 with neutrons in small-scale reactions. Two successive neutron capture ( $n,\gamma$ ) reactions occur, giving plutonium-241 (half-life of 14.3 years), followed by beta decay, yielding americium-241 (Fig. 1).

The details of the science were very subtle, prompting Seaborg to remark in a retrospective about americium and curium, “The understanding and interpretation of the results took place over a longer period of time and had more of the ingredients of a detective story than was the case for the other elements in whose discovery I had the privilege to participate.” If you want to read more about this particular “detective story,” you can find it in *The Transuranium People: The Inside Story* (2000) by Seaborg, Ghiorso, and Darleane Hoffman.

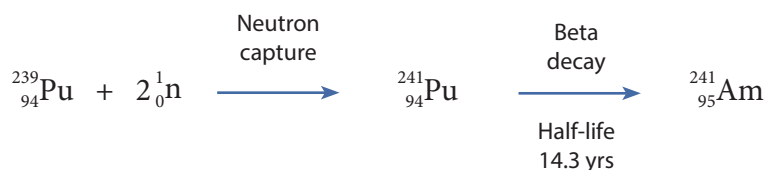

**Figure 1.** Americium was first discovered by bombarding plutonium-239 with neutrons in work performed in the Manhattan Project in 1944.

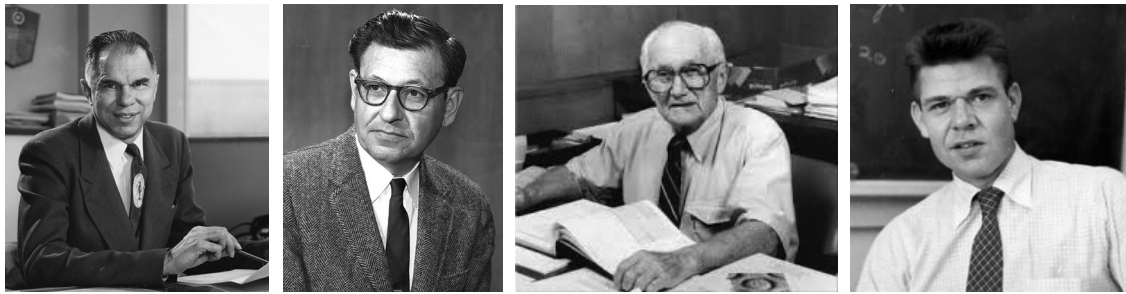

**Figure 2.** Discoverers of americium, *left to right*: Glenn Seaborg, Albert Ghiorso, Leon (Tom) Morgan, and Ralph James.  
 Courtesy: Lawrence Berkeley National Laboratory, courtesy of AIP Emilio Segrè Visual Archives



**Figure 3.** Glenn Seaborg unexpectedly announced the wartime discovery of the new element americium not in a scientific forum, but on the children's radio show *Quiz Kids* (November, 1945). He decided to let the news slip because it had been declassified for an official presentation at an upcoming symposium.



**Figure 4.** The Rocky Flats Plant in Golden, Colorado manufactured americium-241 for commercial sales from 1962 to 1984. The pit production facility was subsequently closed in 1989 due to safety infractions. By 2004, the remaining inventory of americium was depleted, leaving the US dependent on Russian supplies.





**Figure 5.** Americium-241 finds applications in smoke detectors (*left*), neutron moisture meters (*center*), and radioisotope thermoelectric generators (RTGs) for space exploration. *Right:* Artist's impression of a European Space Agency (ESA) Argonaut mission on the Moon. These missions, scheduled for launch in the 2030s, will use an americium-241-powered RTG to eliminate the need for solar panels and allow exploration of regions with little or intermittent sunlight.

Courtesy: ESA.

The announcement of these wartime discoveries came in an unorthodox manner the following November (1945) when Seaborg was invited as a guest scientist on the children's radio show *Quiz Kids*. One of the children asked whether any new elements other than plutonium and neptunium had been discovered at the Metallurgical Laboratory in Chicago during the war. Seaborg replied, "Oh yes, Dick. Recently there have been two elements discovered—elements with atomic numbers 95 and 96. So now you'll have to tell your teachers to change the 92 elements in your schoolbook to 96 elements." This announcement was unplanned, but Seaborg decided to answer Dick's question because the information had already been declassified for an official presentation at an American Chemical Society symposium in five days' time. By analogy with the naming of its rare earth homologue, europium, after Europe, element 95 was named americium after the Americas.

Americium-241 was first made commercially available in 1962 by the US Atomic Energy Commission, manufactured at the Rocky Flats Plant in Golden, Colorado as a byproduct of plutonium processing. Production ceased in 1984, and the pit production facility was closed in 1989. By 2004, the remaining inventory of americium was depleted, leaving the US dependent on Russian supplies.

### Properties and hazards

Americium-241 has a half-life of 432.2 years, decaying primarily through alpha emission to give neptunium-237 (Fig. 6). The second most common mode of decay is spontaneous fission, giving fission products and gamma rays. As such, the isotope is an essentially monoenergetic, high-energy alpha emitter (5.4–5.5 MeV) and a source of soft gamma radiation (59.5 keV); it has a specific activity of 3.43 Ci/g. As an alpha emitter, it does not pose a significant radiological risk unless taken internally, however the gamma radiation creates a significant external dose. Gloveboxes that are equipped to process americium-241 must therefore be heavily shielded with lead or equivalent material.

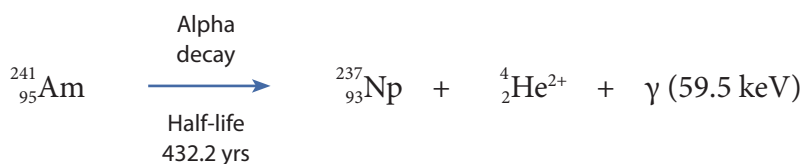

**Figure 6.** Americium-241 decays primarily through alpha decay to give neptunium-237. This reaction is the basis of operation for smoke detectors.

## Americium-241 uses

Americium-241 is mainly used for its alpha emission, which is essentially monoenergetic and high energy (~5.4 MeV), although it has also been used in instruments as a source of soft (i.e., low penetrating) gamma rays. The most widespread use of its alpha radiation is as an ionization source in smoke detectors, where it is used in vanishingly small quantities—on a sub-microgram scale. Americium-241 is preferred over its alternative radium-226 because it emits five times more alpha particles and relatively little harmful gamma radiation at that scale. By ionizing the air, alpha radiation from americium enables an electric current to flow between two electrodes in a smoke detector—when smoke particles enter the detector, they block the current, and an alarm is sounded.

Another major use of americium-241 is as an indirect source of fast neutrons. Americium produces fast neutrons when paired with beryllium—the actinide acts as an alpha source in an (α,n) reaction. Beryllium is used because it possesses a large cross section for the (α,n) reaction, which then produces carbon-12 resulting from alpha particle capture (Eqn. 2, right). This is an extremely cheap and convenient source of fast neutrons compared to nuclear reactors or particle accelerators and can be used in hand-held diagnostic tools.

Fast neutrons have an important application in neutron moisture meters, which are among the most accurate devices available for measuring moisture content of soil (Fig. 5). By coupling a fast neutron source with a neutron detector, a device can provide an estimate of the amount of hydrogen present and therefore the amount of water. In the oil and gas industry, the Am-Be neutron probe is used in a similar fashion for well logging, i.e., creating a record (a well log) of the geologic formations penetrated by a borehole. In this type of neutron porosity log, the hydrogen atoms of hydrocarbons, both liquid and gas, are detected along with water. The porosity values describe how economically feasible the well could be by estimating the ease with which hydrocarbons will flow through the rock. The Am-Be neutron source is also used in imaging techniques such as neutron radiography and tomography, using fast neutrons in the place of X-rays.

As a gamma source, americium-241 has found use as an X-ray excitation source, yielding essentially monoenergetic X-rays whose energy can be tuned. Examples of these applications include materials analysis, using radiography

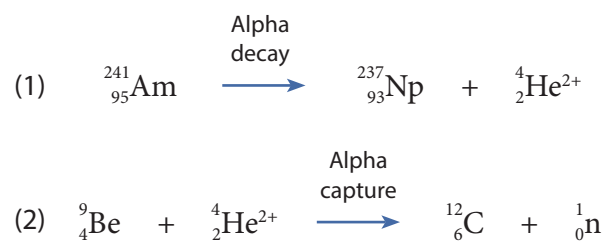

Alpha decay of americium-241 (1) can produce neutrons when paired with beryllium-9 (2), which captures the alpha particles in an (α,n) reaction.

and X-ray fluorescence spectroscopy, and nuclear densitometry in the civil construction, mining, and petroleum industries. The latter technique gauges a material's density or thickness, for instance in soil and asphalt compaction tests for quality control or in industrial gauging where it is used to determine the thickness of plate glass, metals, and wire.

Americium-241 has been proposed as an alternative to plutonium-238 for use in radioisotope thermoelectric generators (RTGs), a type of nuclear battery that has no moving parts, used for unmanned applications such as space missions and remote lighthouses. In these applications, the power source is simply the heat generated by radioactive decay. In November 2022, the European Space Agency (ESA) approved funding for a program to develop americium-powered RTGs in the 10–50 watt range for a series of Moon missions planned for the early 2030s. In the past, the ESA has been reliant on US or Russian partners for supply of plutonium-238, but has since severed ties with Russia after the country invaded Ukraine in February 2022. Due to limited supplies of plutonium-238, they have chosen americium-241 as an alternative radioisotope for their RTG program on the grounds of availability and cost: it can be extracted by reprocessing used nuclear fuel and is five times cheaper per watt of power than plutonium-238. However, americium-241 produces less power per gram due to its longer half-life (432 versus 88 years). The ESA plans to use aged reactor-grade plutonium from the UK, originally containing about 10–14% plutonium-241 as precursor, to recover the americium-241.

### DOE Isotope Program

The Department of Energy Isotope Program (DOE-IP) has its roots going back to the early days of isotope manufacture following the Manhattan Project. Today, the program manages the federal isotope industry, taking care of production and distribution of isotopes that are in short supply as well as maintaining infrastructure and conducting a portfolio of research and development that has been growing rapidly. The program has the sole authority within DOE to produce isotopes for sale and distribution (see [www.isotopes.gov/catalog](http://www.isotopes.gov/catalog)), with the exception of molybdenum-99, plutonium-238 for radioisotope thermoelectric generators, and special nuclear material produced for defense program purposes, which are handled by the National Nuclear Security Administration and the Office of Nuclear Energy. Money brought in from sales is used to reinvest in isotope production.

A key part of the Isotope Program mission is to reduce US dependency on foreign isotope supplies to ensure national preparedness. Through these efforts, which have substantially increased in the last decade, the program has now mitigated the dependence of many isotopes for which we previously relied on foreign countries. This includes americium-241. In 2009, the Isotope Program recognized the risks in the supply chain and provided support to a small team of researchers at Los Alamos to reestablish domestic production capability. Thanks to this funding, Los Alamos plutonium workers at TA-55 began work in 2017 to establish a new processing line at the Plutonium Facility (PF-4) to isolate americium-241 and convert it to an oxide for research and commercial sales.

### Americium-241 recovery at TA-55

Americium-241 may be a desirable product in many industrial applications but at TA-55 it is an unwanted radioactive impurity that creates additional gamma radiation dose in aged plutonium materials, causing increased risk to workers and making downstream processing more complicated. It grows into nuclear waste streams and plutonium stockpiles at a rate that can be calculated by the quantity of plutonium-241 isotope originally present in the sample, along with its age. Plutonium-241 has a half-life of 14.3 years, producing americium-241 as its decay product at an approximate 5% annual rate (atom basis). Roughly speaking, this means that after 20 years, 1 kg of fresh weapons-grade plutonium will contain around 6 g of americium-241.

Virtually all plutonium operations at Los Alamos occur within PF-4, a 233,000 square-foot Hazard Category 2 defense nuclear facility. A significant proportion of this work involves chemical processing of plutonium metal or its compounds, such as plutonium dioxide (see *Actinide Research Quarterly* Third Quarter 2008 for more information). This includes aqueous chloride (AQCL) extraction activities, which operate as an alternative to aqueous nitrate (AQN) recovery lines.

The aqueous chloride mission is to recover plutonium and americium from pyrochemical residues, mostly chloride salts that are not appropriate for applications and/or storage. This extraction process generates plutonium oxide, which is suitable for storage, and americium oxide, now for sale through the DOE Isotope Program. The pyrochemical residues that act as feedstock for these processes come from high-temperature pyrochemical techniques used to purify aged plutonium metal or other plutonium sources (as described in the Los Alamos Pit Production Flowsheet, Fig. 12). A step in the process removes americium-241 ingrowth from the metal, giving an impure byproduct salt which becomes the feed for recovery of plutonium and americium along with legacy supplies.





**Figure 7.** TA-55 is the nation's most modern plutonium science and manufacturing facility, and is the only fully operational, full-capability plutonium facility in the country. It supports a wide range of national security programs which involve stockpile stewardship, plutonium processing, nuclear materials stabilization, materials disposition, nuclear forensics, nuclear counterterrorism, and nuclear energy.

Recovery of plutonium and americium is achieved using two chemical extraction lines contained within radiological gloveboxes. The experimental chloride extraction line (EXCEL) has operated since 1993 to purify plutonium materials through aqueous chloride extraction. More recently in 2017, the chloride line extraction and actinide recovery (CLEAR) glovebox system was added downstream of EXCEL for americium-241 oxide recovery and purification. Extractions are typically performed on a multigram scale.

The EXCEL/CLEAR process consists of the following six main steps:

1. **Dissolution.** Plutonium solids (pyrochemical residues) are dissolved in aqueous hydrochloric acid, giving the primary species plutonium(III) chloride plus americium(III) chloride and other impurities.
2. **Separation.** Plutonium, americium, and impurities are separated using either solvent extraction (SX) or anion exchange (IX) methods. Two streams are created, one containing plutonium(IV) and the other americium(III).
3. **Americium-241 purification.** The first stage in the CLEAR process, using preparative-scale chromatography to extract americium from the waste stream created by the previous plutonium separation process.
4. **Precipitation.** Oxalate precipitation using oxalic acid is used in both streams:
  - (i) **Plutonium stream:** Hydroxylamine hydrochloride is used as a reducing agent which converts the plutonium(IV) to plutonium(III). Oxalic acid is then added to precipitate plutonium oxalate.
  - (ii) **Americium stream:** A reducing agent is not necessary here as the americium is already in the appropriate (trivalent) oxidation state. Oxalic acid is added to precipitate americium oxalate.
5. **Calcination.** Plutonium and americium oxalate cakes are calcined to create the respective tetravalent oxide products. Plutonium is calcined in a tube furnace, americium in a muffle furnace.
6. **Hydroxide precipitation.** This step isolates and reduces the volume of radioactive waste products for disposal. The waste product wash solutions from SX/IX streams (step 2) and filtrate from the plutonium and americium oxalate precipitation (step 4) are combined and neutralized with potassium hydroxide, resulting in hydroxide precipitation. These solids are then calcined as described above to produce solid waste for radioactive disposal and a discardable caustic stream.

### Separation: Solvent extraction (SX) versus anion exchange (IX)

The EXCEL process can be performed with either solvent extraction (SX) or anion exchange (IX) separation methods. In solvent extraction, a biphasic aqueous-organic extraction method is used. Using a motorized set of cylindrical “contactors,” the acidic aqueous stream containing dissolved plutonium and americium contacts an organic phase and separates naturally by density. The organic phase extracts plutonium using tributylphosphate (TBP) in a diluent of dodecane and decanol, similar to the PUREX (plutonium uranium reduction extraction) process for recovery of plutonium and uranium from spent nuclear fuels. The contactors are specially designed vessels that mix and separate the phases, allowing the process to be automated with continuous flow. The system uses several washing steps and eventually re-extracts the plutonium into an acidic aqueous phase using a total of eight contactors. The americium meanwhile is retained in the produced liquid, or raffinate, along with impurities for separate purification in CLEAR.

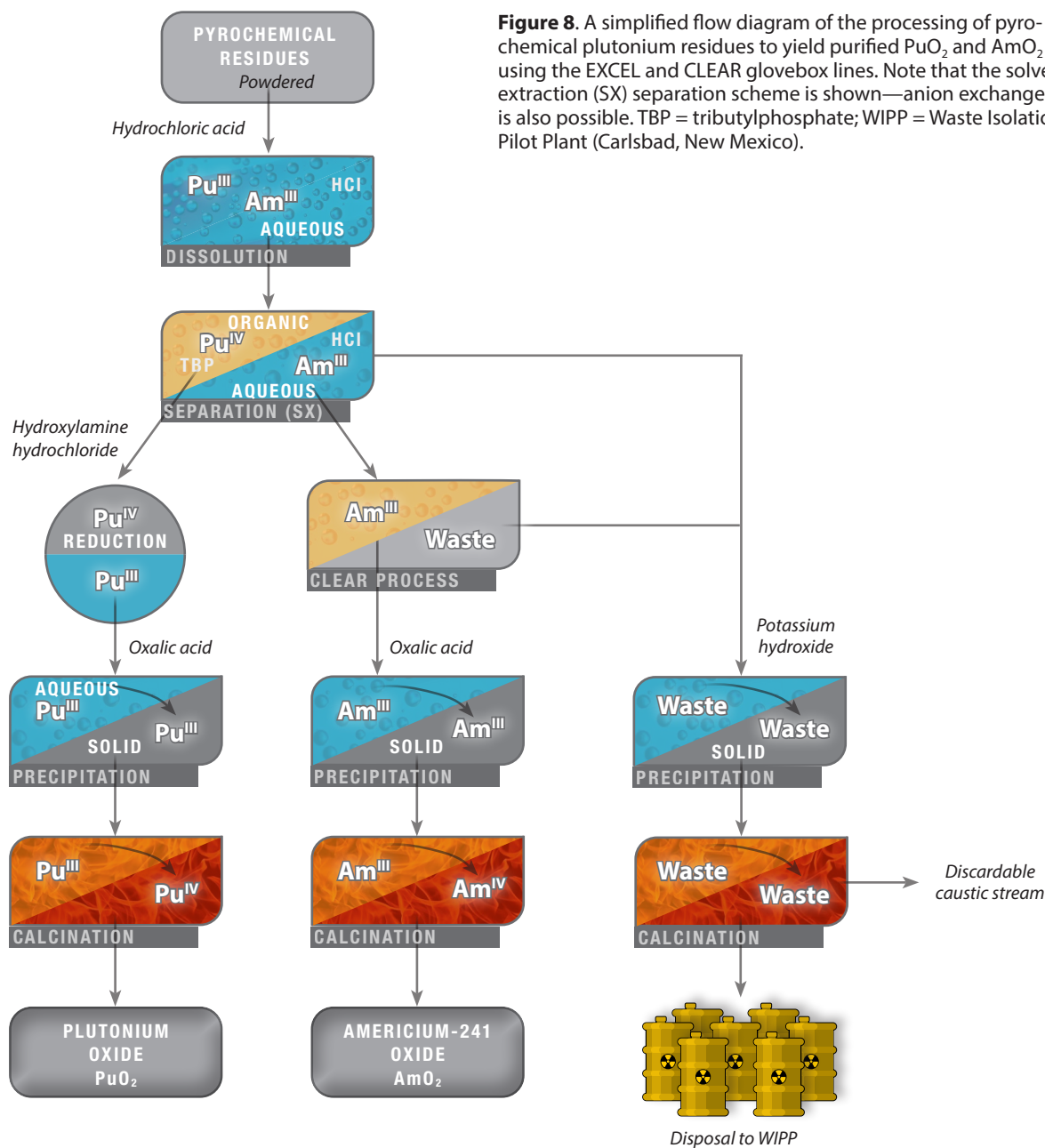

**Figure 8.** A simplified flow diagram of the processing of pyrochemical plutonium residues to yield purified PuO<sub>2</sub> and AmO<sub>2</sub> using the EXCEL and CLEAR glovebox lines. Note that the solvent extraction (SX) separation scheme is shown—anion exchange (IX) is also possible. TBP = tributylphosphate; WIPP = Waste Isolation Pilot Plant (Carlsbad, New Mexico).

In the anion exchange process (IX), preparative-scale column chromatography is used in which plutonium and americium adsorb to different resins and are separated from waste products which are washed through the column. Once the actinides are washed, they are extracted using a low concentration HCl solution. Four columns are required using Reillex™ HPQ ion exchange resin, a material developed in the late 1980s through a collaboration between Los Alamos and private industry. Compared with earlier anion-exchange resins, HPQ has improved sorption properties for plutonium and is less prone to radiolytic or chemical degradation in harsh acidic conditions containing high concentrations of alpha-emitting plutonium isotopes. The enhanced stability of Reillex™ HPQ allows the resin to be used for approximately 50 plutonium recovery cycles before being replaced.





**Figure 9.** Column chromatography line in CLEAR process, used to extract americium-241 from a waste product stream in the EXCEL process.

• • •

Despite being more labor-intensive, solvent extraction (SX) is currently the preferred system due to the better processing rate and higher capacity of nuclear material compared to anion exchange (IX). The latter requires running the process multiple times to purify a single batch, making it slower overall and producing more waste solution volume.

### **CLEAR: Extraction chromatography**

The key step in the CLEAR process is extraction chromatography, similar to the anion exchange step. A LANL-developed phosphine oxide extractant (m-CMPO, di-(4-t-butylphenyl)-N,N-di-iso-butylcarbamoylmethylphosphine oxide) is used, which is adsorbed along with a phase transfer catalyst (TBP, or di-amyl amyl phosphate, DAAP) on a polymethacrylate resin bead. Recent research published by LANL researchers in 2021 suggests that changing from an m-CMPO-based resin to a commercially-available diglycolamide resin could make americium-241 recovery efforts more efficient. The diglycolamide resins quantitatively released americium-241 at low HCl concentrations (<0.5 M), were less susceptible to negative side effects from metal contaminants in the mobile phase, and bound americium-241 faster.

### **Americium oxide product**

The stable form of americium-241 that is sold and used in instruments is the dioxide, AmO<sub>2</sub>, which is obtained as a beige-brown powder from the final two steps of the CLEAR process. The first of these steps transforms the chloride into a solid oxalate salt, which readily precipitates. This oxalate salt is then calcined in a furnace at high temperature to produce the oxide. This is performed on a much smaller scale than the calcination of plutonium because of the dose inherent with americium-241 and the amounts of daughter isotope present in the original material. Purity of the americium product is then ascertained using thermal ionization mass spectrometry (TIMS) to ensure it reaches minimum specifications (Table 1). Finally, the powder is blended for even particle distribution and packaged in a set of specially designed nested containers such as SAVY-4000, a vented, general-use nuclear material container.

Several sub- to multi-gram shipments of AmO<sub>2</sub> product have been recovered by the Los Alamos americium-241 team since 2017 and made available for isotope sales through the DOE Isotope Program's National Isotope Development Center (NIDC). The team that achieved this goal includes past and present members from AMPP-4,



**Figure 10.** Above: Plutonium(III) oxalate (green) and americium(III) oxalate (yellow) prior to being calcined in a furnace (*far right*). This process yields the tetravalent oxides, which are the final products in the overall EXCEL/CLEAR purification process.



**Figure 11.** Left: The  $^{241}\text{AmO}_2$  product is packaged in a set of specially designed nested containers for transport.

**Table 1.** Material specifications for the  $^{241}\text{AmO}_2$  product for normal use (National Isotope Development Center).

Quantity	Specification
$^{241}\text{Am}$ isotopic purity	$^{241}\text{Am} > 99\%$ of all Am by weight
$^{241}\text{AmO}_2$ chemical purity	$> 95\%$ by weight from NDA methods
Plutonium content	$< 1.0\%$ by weight from NDA methods

\* NDA = nondestructive assay



AMPP-3, ORI-2, and MST-16: Victor Salazar, Richard Salazar, Brenda Griego, David Kimball, Casey Finstad, Louis Schulte, Mary Ann Stroud, Brad Skidmore, Hope Quintana-Martinez, Gabrielle Ambrosio, Chris Lopez, Garrett Fulcher, Sheldon Apgar, and Andrew Wiggins.

Collaborations with other teams and organizations within LANL have dramatically improved several aspects of the CLEAR process. For instance, with the recent project described above that identified better extraction resins to increase the efficiency of americium-241 recovery. Since the inception of the CLEAR process, the aqueous chloride plutonium and americium recovery team has sought to increase yearly throughput of americium-241 oxide recovery and waste minimization. Successes with extraction resins and precipitation parameters are enabling this goal.

Interest in americium-241 recovery as part of the PF-4 pyrochemical flowsheet has increased with the 30 pits per year (30PPY) LANL mission. More pits create more

pyrochemistry, which entails processing more pyrochemical byproducts—all carrying significant quantities of americium-241. Ideally, to keep up with byproduct (waste) generation, EXCEL and CLEAR operations must become faster and more efficient.

Efforts are underway to streamline the CLEAR process and increase recovery of americium-241. The extraction chromatography process is still rate limiting in the CLEAR flowsheet, however improvements here have the potential to both speed up recovery rates and increase recovery amounts. Initial results using selective precipitations to purify the majority of the americium-241 show promise to achieve faster rates and larger volumes.

### Summary

In 2009, the Department of Energy Isotope Program (DOE-IP) identified a vulnerability in the supply chain of americium-241 and recommended that domestic production resume from a Los Alamos plutonium waste stream. This isotope is in high demand, particularly in nuclear power sources, research, and as a portable source for medical and industrial applications. In 2012, DOE funded a small team of researchers at Los Alamos to reestablish a domestic production capability: workers at the Plutonium Facility (PF-4) consequently developed a new glovebox system: the chloride line extraction and actinide recovery (CLEAR) line. In 2017, operations began that gave the first delivered product of  $^{241}\text{AmO}_2$  in 2020, providing an efficient and effective domestic americium-241 supply that is critical for US research and industry. A secondary but substantial economic benefit also results in removing an unwanted impurity from plutonium residues, which would otherwise be costly to dispose. For instance, waste drums sent to WIPP (Waste Isolation Pilot Plant) in Carlsbad, New Mexico cost around \$100,000 each. Recovery of plutonium and especially americium from the waste reduces its disposal footprint and saves on taxpayer's dollars. Overall, resuming production of americium and mitigating dependency on sensitive countries has been beneficial to all parties involved: the US nuclear complex, taxpayers, and industry. A true win-win!

### Acknowledgments

I am very grateful to David Kimball for offering his expertise and to Kirk Rector, David Bivans, and Jehanne Gillo at the DOE-IP for additional feedback.

#### *Further reading*

1. B.T. Arko, D. Dan, S.L. Adelman, D.L. Huber, D.B. Kimball, S.A. Kozimor, M.N. Lam, V. Mocko, J.C. Shafer, B.W. Stein, S.L. Thiemann, "Characterizing extraction chromatography for large-scale americium-241 processing," *Ind. Eng. Chem. Res.* 2021, 60, 14282.
2. D.C. Hoffman, A. Ghiorso, G.T. Seaborg, "The Transuranium People: The Inside Story," Imperial College Press, London, 2000.
3. *Actinide Research Quarterly*, Third Quarter 2008.



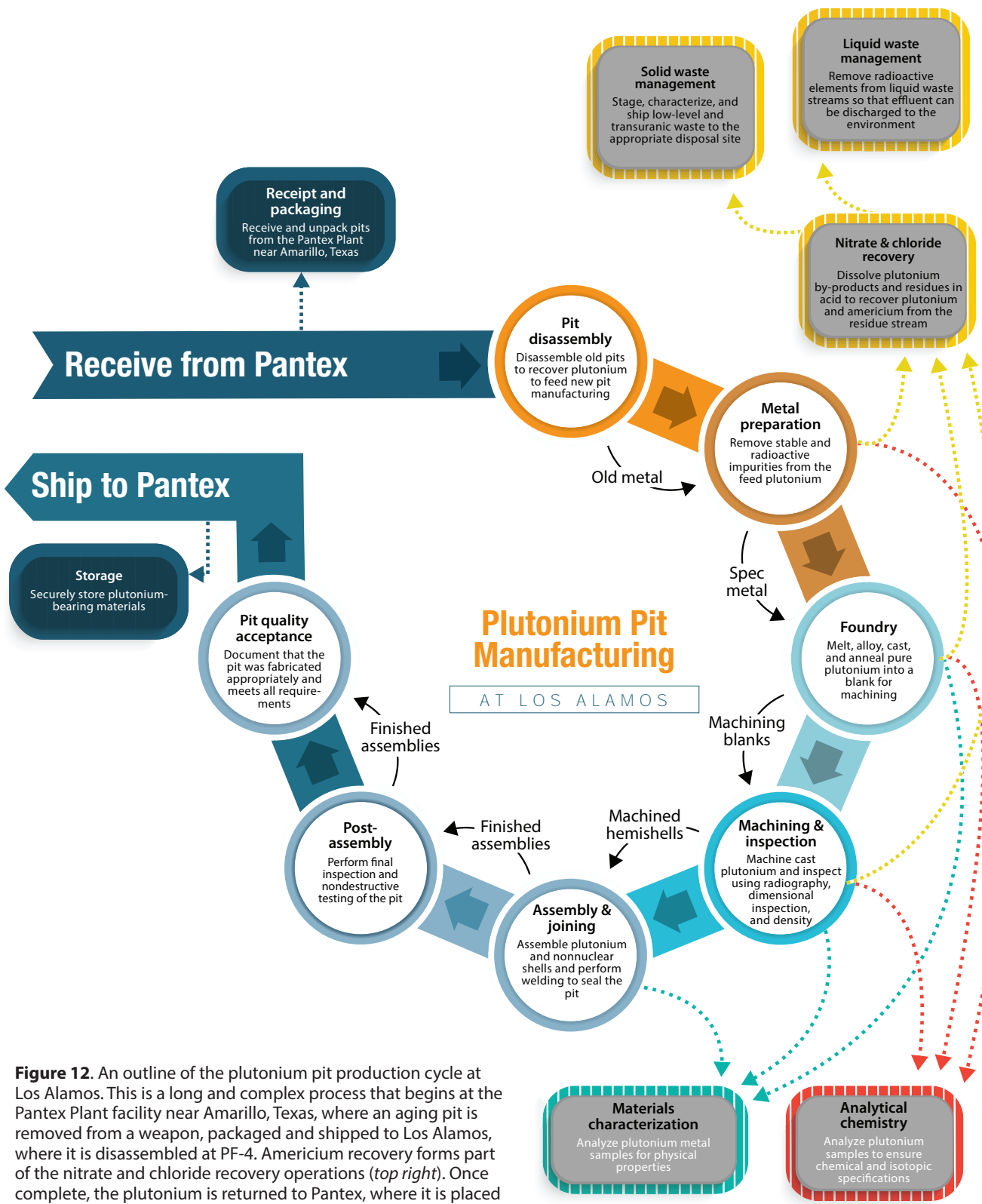

**Figure 12.** An outline of the plutonium pit production cycle at Los Alamos. This is a long and complex process that begins at the Pantex Plant facility near Amarillo, Texas, where an aging pit is removed from a weapon, packaged and shipped to Los Alamos, where it is disassembled at PF-4. Americium recovery forms part of the nitrate and chloride recovery operations (*top right*). Once complete, the plutonium is returned to Pantex, where it is placed back into a stockpiled weapon. By 2026, Los Alamos expects to produce at least 30 plutonium pits per year.  
 Courtesy: Brenda Fleming, *National Security Science magazine*.

# DOE Funding for Advanced Nuclear Reactors

In the face of the climate crisis—arguably the biggest challenge humanity has ever faced—an enterprising “all hands on deck” spirit has emerged for developing energy technologies, both new and old. As such, support for nuclear energy has undergone a dramatic U-turn: most experts agree that short-term decarbonization of the global economy will be impossible without developing nuclear power. Nuclear fission has a very low carbon footprint, is weather-independent, can directly replace fossil-fuel-powered plants, and is more scalable than renewables—factors that have led many prominent energy investors such as Bill Gates to push for nuclear power as an essential component of the solution to the climate crisis.

The types of nuclear power plants that Gates and others are backing are, however, fundamentally different from the old generation of light-water reactors, whose designs date back many decades. New designs, termed advanced reactors, vary greatly and offer many benefits, including better safety and a reduced cost and waste footprint. While the private industry pushes forward with building these new reactors, the federal government has been working in a coordinated effort to support the successful development and deployment of this advanced technology.

In this article, we highlight some of the research that is underway as part of two Department of Energy (DOE) Advanced Research Projects Agency–Energy (ARPA-E) programs related to advanced reactors: **ONWARDS** (Optimizing Nuclear Waste and Advanced Reactor Disposal Systems) and **CURIE** (Converting UNF Radioisotopes Into Energy).

## Nuclear decline

Nuclear power already provides about 20% of the electricity in the US, or about half the nation’s carbon-free energy. However, many US nuclear reactors are shutting down prematurely: 12 have permanently closed since 2012, with many more at risk of retirement in the coming years. This decline is not new—the number of nuclear units has been decreasing since 1990. This is because they are comparatively cost-intensive in some markets—the cost of nuclear energy has spiked in recent years, peaking in 2012, in part from increasing regulations to address public safety concerns—and also because they have been maligned for perceived environmental impacts as well as potential terrorism risks. Unfortunately, when a reactor is shut down, the lost electricity is usually replaced by fossil fuel sources. A recent article in Vox described how the Indian Point reactor in New York state, which closed down in spring 2021, was replaced largely by natural gas. With each nuclear reactor shutdown, we make backwards progress on our essential carbon-reduction commitments.

The problems causing the decline are far from intractable, however. The majority of reactors in the current US reactor fleet are of Generation II design (1965–1996). Generation III (1996–2016) and IV (2016–present), also known as advanced reactors, offer significant improvements which tackle safety, cost, and waste issues. Specifically, these include improvements in fuel technology with reduced waste, higher thermal efficiency, significantly enhanced safety systems (including passive nuclear safety), stronger reinforcement against improbable aircraft attacks, longer operating lifetimes, and standardized designs intended to reduce maintenance and capital costs.

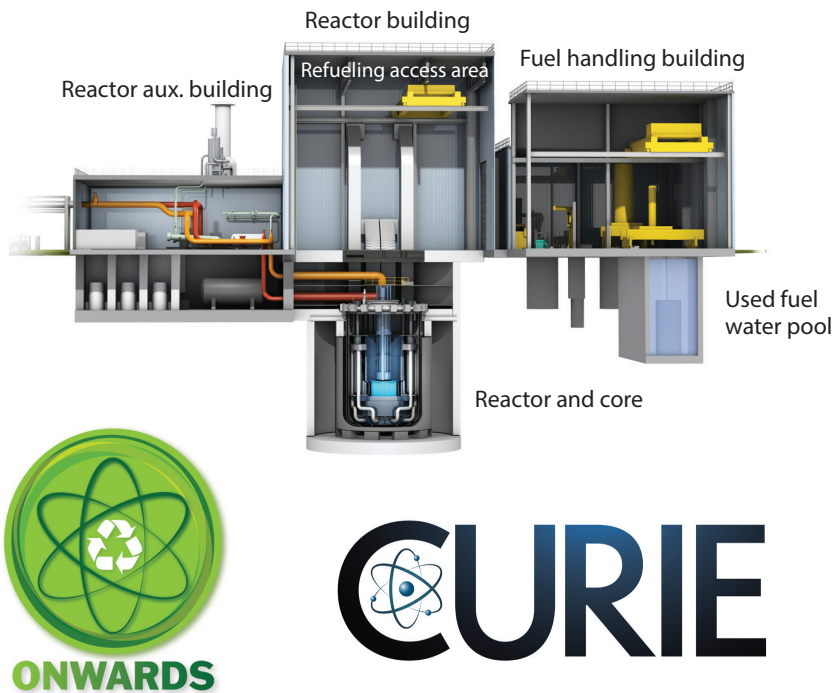

TerraPower's proposed Sodium advanced reactor, a 345 MWe sodium fast reactor using HALEU metal fuel. Construction of the first units is hoped to begin in 2025 and be completed by 2030, making it one of the first commercially available advanced nuclear technologies in the US.  
*Courtesy: TerraPower, DOE.*

Two DOE ARPA-E programs, ONWARDS and CURIE, aim to develop new technologies that support the deployment of advanced nuclear reactors.



Advanced reactor designs can be broadly grouped into two types: those cooled by water, such as the small modular reactors, and those that are not, such as molten salt reactors (which use fluoride and chloride salts), sodium-cooled reactors, high-temperature gas-cooled reactors, gas-cooled fast reactors, and micro-reactors.

### What are the problems with advanced reactors?

Although advanced reactors promise to solve many of the problems associated with conventional nuclear plants, they also create new challenges that need to be addressed, varying from the specific fuel details through to global issues concerning infrastructure. For instance, some advanced reactor designs use conventional fuel but at higher enrichment: high-assay low-enriched uranium (HALEU), containing 10–20% uranium-235. There has been little investment in HALEU production infrastructure in the US and Europe, and the main supplier is currently Russia. Lack of investment in the domestic market comes down to a chicken-and-egg situation—investors want to see robust demand first, but advanced reactor technology is stalled without a consistent supply of the fuel.

Another question regards fuel recycling, or reprocessing. Our used nuclear fuel—currently 86,000 metric tons stored in spent fuel pools and dry casks at more than 70 reactor or former reactor sites across the country—is destined for permanent disposal, even though more than 90% of its energy remains. Although the US does not currently recycle spent fuel, several foreign countries do (notably France, Russia, and Japan), creating mixed-oxide (MOX) fuel, a mixture of fissile plutonium and uranium oxides. This increases the efficiency of the original uranium fuel by 25–30% and reduces the volume of high-level waste to about one-fifth. It also reduces overall radioactivity levels in the waste. Despite these benefits, it has been argued that reprocessing increases proliferation risk by encouraging increased separation of plutonium from spent fuel in the civil nuclear fuel cycle. For this reason, President Carter



banned the technique in 1977 after India demonstrated nuclear weapons capabilities using reprocessing technology in the previous year. Although Carter intended the US to set example for the world, discouraging domestic reprocessing has had minimal effect on the policies of foreign countries.

In 1981, President Reagan lifted the moratorium. However, reprocessing continued to be viewed unfavorably by following administrations and no investment was made in the technology until 1999 when the DOE commissioned a MOX fabrication facility at the Savannah River Site, which was designed to reprocess Cold War-era plutonium pits extracted from decommissioned weapons. The facility was terminated in 2021 due to escalating costs and missed construction deadlines. To date, although three civil reprocessing plants were built before 1977, the US has not yet recommitted to recycle spent nuclear fuel and thus close the US nuclear fuel cycle.

### Waste disposal: Advanced reactors change the equation

Waste disposal is one of the most persistent challenges in nuclear energy. Although waste generated by conventional light-water reactors is a known quantity and has an established disposal path, this path is widely criticized as inefficient and unsustainable, and a final repository location for high-level waste has yet to be decided on in the US. Advanced reactor technologies, however, change the equation. On the one hand, they provide new opportunities for innovation that could lead to lower waste volumes and better management. The ONWARDS program, for instance, aims to reduce waste by a factor of tenfold compared to conventional nuclear reactors and provide waste forms for new fuel cycles. On the other hand, these technologies may potentially create new problems. One study from Stanford researchers in 2022 indicated that some prototype small modular reactor designs could create nine times more neutron-activated steel than conventional power plants due to neutron leakage. Although this is not the final conclusion for advanced reactor technology, it highlights the need for research and development in the back end of the nuclear cycle.

### ARPA-E funding programs

In 2018, MIT released an influential study, *The Future of Nuclear Energy in a Carbon-Constrained World*, emphasizing the need for coordination between federal government and industry to successfully develop nuclear energy in the 21st century. To this end, DOE has recently provided billions of dollars in funding to support development and deployment of advanced reactors in support of carbon-free energy, particularly focused on problems which are not easily solved by industry alone. As part of this effort, ARPA-E has established a suite of complementary programs:

<b>MEITNER</b> 2018	Awards funds to enable designs for lower cost and safer advanced reactors.
<b>GEMINA</b> 2019	Supports projects that use advanced computing techniques to model reactor operations for existing nuclear plants to bring down fixed operations and maintenance costs.
<b>ONWARDS</b> 2021	Examines the back end of the nuclear cycle, aiming to reduce waste volumes from advanced reactors and address related issues such as reprocessing, safeguards, and waste forms.
<b>CURIE</b> 2022	Seeks to develop technology relating to used nuclear fuel reprocessing (including chemical separations and facility designs), material accountancy, and online monitoring techniques.

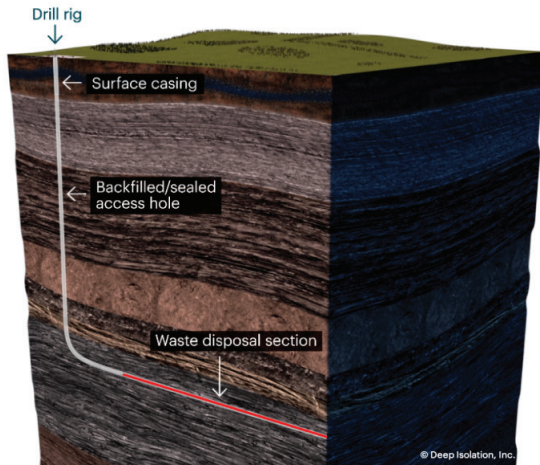

Deep Isolation is developing a directional borehole technology in support of deep geological disposal of nuclear waste, allowing for expanded location options for repositories.

*Courtesy: Deep Isolation.*

## ONWARDS program

ONWARDS ambitiously aims to reduce waste from advanced reactors by a factor of tenfold compared to light-water reactors, either as a total of waste volume generated or as reduction in size of repository footprint. The program targets both open (once-through) and closed (reprocessing) fuel cycles, investigating issues relating to reprocessing, recycling, safeguards, and waste forms. Specifically, funding has been given to projects that reduce waste volumes, increase fissile fuel use, improve accountability of nuclear materials and their intrinsic resistance to proliferation, bolster advanced reactor commercialization, and develop high-performance waste forms suitable for all advanced reactor classes.

In March 2021, ONWARDS provided \$36 million in funding for 11 new research projects, led by universities, private companies, and national laboratories: General Electric Global Research, TerraPower, Citrine Informatics, Rutgers University, Rensselaer Polytechnic Institute, Orano Federal Services, Brigham Young University, Idaho National Laboratory, Oklo, Stony Brook University, and Deep Isolation. Three of these projects are highlighted below.

### Idaho National Laboratory

Researchers at Idaho National Laboratory (INL) aim to develop a waste recycling method for metallic fuels used in several advanced reactor designs. These metallic fuels are similar to those used in early experimental fast reactors, such as Clementine (plutonium metal; see *Actinide Research Quarterly* Second Quarter 2022) and EBR-II (zirconium-uranium alloys). The researchers conceived their idea when they examined historical data and noticed that when this type of spent fuel was heated, there was a natural phase separation between the layers, separating actinide, lanthanide, and alkaline earth components, along with precipitation of alkali metal solids.

By using a zone-refining furnace, which works using magnetic induction, used fuel can be melted with precision control to achieve phase separation and extraction of the high-level radioactive waste. A small-scale device has already demonstrated proof of concept with simple uranium slugs, but the team will expand this work to examine used fuel surrogates and look at ways to improve the technique, as well as gauge its economic feasibility.

## Reprocessing and proliferation: What's the risk?

The primary proliferation concerns associated with civilian nuclear programs come from uranium enrichment, which gives the most straightforward access to fissile materials that can be used in a nuclear weapon. Nevertheless, reprocessing still represents a risk in the eyes of many experts, as it often involves separation of plutonium, and some maintain that the best protection of the back-end of the fuel cycle is to forego reprocessing entirely.

About 1% of used fuel from light-water reactors is made up of plutonium, and around one-half to two-thirds of this is fissile (plutonium-239 and plutonium-241). However, a significant amount of the remainder is made up of plutonium-240: reactor grade plutonium is defined as plutonium with 19% or more of plutonium-240 (sometimes known as “civil plutonium”). This isotope is extremely problematic for weapons use as it has a high rate of spontaneous fission, with accompanying neutron emission. As recognized during the Manhattan Project, a weapon made from high plutonium-240 would result in a high neutron flux when triggered, causing a predetonation, or a “fizzle.” However, a lower yielding “fizzle bomb” could still cause significant damage in an urban area. Therefore, the IAEA conservatively classifies all isotopes of plutonium as “direct-use” material, that is, “nuclear material that can be used for the manufacture of nuclear explosives components without transmutation or further enrichment.”

In response, treaties and safeguards have been put in place by the IAEA to protect the back end of the fuel cycle from proliferation risks (safeguards are activities that allow the IAEA to verify compliance of commitments not to use civil nuclear programs for weapons purposes). MOX is widely used in light-water reactors in Europe and Japan (40 reactors in Europe and 10 in Japan). China and Russia meanwhile are new countries to embark upon MOX use, albeit with a focus on fast reactors. All of these reprocessing facilities are government-run entities that adhere to IAEA protocols.

### Breeder reactors

A breeder reactor is a type of advanced reactor that generates more fissile material than it consumes. Specifically, fast breeder reactors generate plutonium from a uranium-238 blanket that surrounds a MOX or high-enriched uranium (HEU) core. At present, there are only two commercially operating breeder reactors worldwide, both Russian sodium-cooled reactors, but three of the six Generation IV reactor designs currently under development are fast breeder reactors.

Some breeder reactor designs can include schemes which separate plutonium-239 (i.e., weapons-grade plutonium) using the PUREX process, which could present significant security and safeguards challenges—far more serious than those posed by reactor-grade plutonium—leading to potential problems with nonproliferation treaties. New reprocessing methods are however being designed that do not isolate fissile plutonium. These methods are specifically targeted by the DOE ONWARDS and CURIE programs where no pure fissile stream is generated throughout the processing.

### Reprocessing schemes

Reprocessing is no different in principle to any scheme that separates metals from mineral ore mixtures. There are three overall types of metallurgical treatments used at smelters and refineries:

- **Hydrometallurgy.** This type of reprocessing method uses aqueous solutions to dissolve metals and sometimes also employs electrolytic cells to separate them (e.g., zinc production, copper refining). The PUREX process is a hydrometallurgical process.
- **Pyrometallurgy.** Heat is used to separate metals from their mineral ore (e.g., copper smelting to produce blister copper, lead smelting).
- **Electrometallurgy.** Often called pyroprocessing because it occurs at high temperatures, this uses electric current to separate metals (e.g., alumina smelting to produce aluminum). Electrometallurgical techniques are the main focus of interest for developing future nuclear fuel reprocessing methods, which recover all actinide ions together (i.e., uranium and plutonium) and therefore reduce the risk of proliferation.

In summary, although reprocessing of used nuclear fuel poses some proliferation risk, particularly for transportation, that risk is relatively minor for reactor-grade plutonium and can be reliably safeguarded. Fast breeder reactor schemes that propose using the PUREX process to isolate plutonium-239 are being replaced with improved reprocessing methods that separate actinide fuel components without isolating plutonium. Furthermore, recovery and recycling of plutonium from long-lived waste before deposition eliminates the possibility of plutonium-239 being extracted from used fuel, which may not be reliably safeguarded. As such, reprocessing may actually increase the proliferation resistance of the fuel cycle.





Spent nuclear waste stored in steel-reinforced concrete buildings in Marcoule, France. The Orano MELOX recycling plant in Marcoule produces MOX fuel assemblies made from a blend of uranium oxide and plutonium developed from this spent fuel.

## TerraPower

Using the largest of the ONWARDS grants (\$8.6 million), TerraPower and its collaborators (New Mexico State University, and Idaho and Savannah River national laboratories) aim to develop an experimental method for the recovery of uranium from used nuclear fuel by harnessing the volatility of chloride salts at high temperatures. Chlorination of used nuclear fuels, either oxide-based or metallic, is possible using chlorine gas or carbon tetrachloride at elevated temperatures. The resulting chloride salts have varying levels of volatility at high temperatures, which may allow for bulk separation of uranium from fission products and plutonium, either for recycling or reduced volume waste disposal. This proposal builds on previous chloride-based volatility studies conducted during the Manhattan Project through to the early 1960s, with a new angle of aiming to reduce waste footprints.

By adjusting chloride-based volatility parameters and separating uranium, waste volumes could be reduced by factors of as much as 10–20 times, according to TerraPower. The team aims to improve chlorination rates by optimizing basic process parameters in a way that would also be suitable for scale-up in a commercial-scale facility. They will start with surrogate oxide used nuclear fuels to synthesize chloride salt mixtures and then later will demonstrate the method using actual used nuclear fuel.

## Deep Isolation

Deep Isolation, in partnership with the University of California, Berkeley, Lawrence Berkeley National Laboratory, and NAC International, received a \$3.6 million grant to develop a novel universal canister system for advanced reactor waste streams. This canister will be suitable for storage, transportation, and long-term geological disposal of high-level waste, eliminating the difficulties and cost of repackaging between sites.

The design will account for the nuclear industry's current dry storage and transportation infrastructure and will meet various waste acceptance constraints across a range of geologic repository options. This includes both conventionally mined tunnels and Deep Isolation's own proposal: a deep borehole repository that leverages directional drilling in which 18-inch holes suitable for accepting the waste canisters could be configured horizontally, vertically, or slanted.

Deep Isolation is also involved with another ONWARDS-funded project, a \$4 million joint venture with Oklo Inc., and Argonne and Idaho national laboratories that aims to perform R&D to develop the first nuclear fuel recycling and disposal facility in the US. The electrorefining facility will ultimately produce fuel for metal-fueled advanced reactors, closing the fuel cycle. Deep Isolation will identify waste forms that will take the waste stream from the electrorefining facility to a deep borehole repository.

### **CURIE program**

The CURIE program aims to develop innovative reprocessing technologies that substantially reduce the volume, heat load, and radiotoxicity of waste requiring permanent disposal. In this regard, the program targets separations technologies and safeguards, including material accountancy and online monitoring technologies. Furthermore, it also seeks to develop a closed fuel cycle in which these technologies provide a sustainable fuel feedstock for advanced fast reactors. To achieve this, CURIE is funding designs for a reprocessing facility that will enable UNF recycle without the generation of pure plutonium streams, incorporate in situ process monitoring, minimize waste volumes, enable a low fuel cost for advanced reactor fuels, and maintain low disposal costs.

In 2022, CURIE provided \$38 million in funding for a dozen projects, similar in scope to the ONWARDS portfolio. Seven of the twelve grants explore methods for recycling used nuclear fuel: University of Alabama at Birmingham, Argonne National Laboratory (two grants), University of Utah, Curio™, INL, and Mainstream Engineering. The remainder focus on safeguards for advanced reactors (GE Research, University of North Texas), materials accountancy (NuVision Engineering, University of Colorado, Boulder), and recycling facility design (EPRI).

### **Summary**

As part of a coordinated federal effort to assist the development and deployment of advanced nuclear reactor technology by the nuclear industry, the DOE ARPA-E division has recently established a suite of four complementary grant programs. Each focuses on a different aspect of the technology: MEITNER funds projects for advanced reactor designs that reduce cost and increase safety; GEMINA supports efforts that reduce reactor operations costs using advanced computer modeling; ONWARDS aims to reduce waste volumes from advanced reactors and address related issues such as reprocessing, safeguards, and waste forms; and CURIE seeks to develop technology relating to used nuclear fuel reprocessing (including chemical separations and facility designs), material accountancy, and online monitoring techniques. A total of \$165 million has been awarded so far by these ARPA-E programs, whose recipients include academic institutions, national laboratories, and private industry.

### **Acknowledgments**

Many thanks to Bob Ledoux and Jenifer Shafer for their expertise.

#### *Further reading*

1. "The Future of Nuclear Energy in a Carbon-Constrained World: An Interdisciplinary MIT Study," "Future of" Series, MIT Energy Initiative, Cambridge, MA, 2018.

# Hitting the Jackpot: The Birth of the Monte Carlo Method

A game of solitaire, a case of insomnia, a chance meeting at a train station, and a penchant for gambling all contributed to the creation of one of the most influential computing tools in the world: the Monte Carlo method. First conceived in 1946 by Stanislaw Ulam at Los Alamos<sup>†</sup> and subsequently developed by John von Neumann, Robert Richtmyer, and Nick Metropolis, the method was first used to calculate neutron diffusion paths for the hydrogen bomb. Since then, its use has exploded into an uncountable number of applications in science and technology, artificial intelligence, finance, transport, health, and manufacturing, along with virtually every profession that must measure risks.

The method is particularly useful for modeling situations with a large number of random variables, for instance, in applications ranging from predicting stock market volatility to modeling the post-detonation nuclear forensics of an electromagnetic pulse (EMP) attack. Modern Monte Carlo codes also underpin the criticality calculations previously described on p2. The original calculations are historically significant as the first programs written in the modern stored-program paradigm to be run on an electronic computer, now the cornerstone of modern computing.

## The virtuoso

Like many European intellectuals of the time, the Polish mathematician Stanislaw Ulam emigrated to the US in 1939 to escape racial persecution from the Nazis. Ulam resented being labeled an intellectual, however. His friend Gian-Carlo Rota said, “He would not even agree to being classified as a mathematician. He referred to the published volume of his scientific papers as ‘a slim collection of poems.’”

Perhaps, as Rota suggests in his reminiscences of Ulam, “virtuoso” would be the best descriptor.

As the war intensified, Ulam began to look beyond his teaching position at the University of Wisconsin for ways he could contribute to the war effort. His first thought was to turn to his friend and fellow Jewish emigre John von Neumann, who he suspected was involved in secret military research. Von Neumann’s uncharacteristic silence on scientific matters spoke volumes to Ulam. His suspicions proved to be correct, and before long Ulam joined the Manhattan Project.

At Los Alamos, Ulam discovered a natural talent for applying his esoteric mathematical skills to solve problems in physics. The divide he was attempting to bridge was real—he would joke that “the mathematicians know a great deal about very little and the physicists very little about a great deal.” After watching Enrico Fermi and Richard Feynman at the blackboard, he was inspired to emulate their approach by solving real-world problems with the minimum amount of math. Ulam went on to make major contributions to the design of the hydrogen bomb, solving the problem of how to initiate fusion, although he clashed with its other main designer, Edward Teller.

<sup>†</sup> Here and throughout, “Los Alamos” refers to Los Alamos National Laboratory in its precursor forms, known as Project Y 1943–46 and Los Alamos Scientific Laboratory (LASL) 1947–81.





**Figure 1.** *Top left:* Stanislaw Ulam. *Top right:* John von Neumann. *Bottom:* John von Neumann, Richard Feynman, and Stanislaw Ulam on the porch of Bandelier Lodge near Los Alamos during a picnic, circa 1949. Von Neumann always wore a suit regardless of occasion! *Courtesy: Charles A. Lehman Photography, Los Alamos Photographic Laboratory, AIP Emilio Segrè Visual Archives, Physics Today Collection.*

*“I am thinking about something much more important than bombs; I am thinking about computers.”*

— John von Neumann, 1945.

## Misfortune in the cards

After the war, Ulam had found himself in a pedestrian teaching job in California when he abruptly began to experience discombobulating headaches. He said that he “remembered suddenly Plato’s description of Socrates after he was given the hemlock in prison; the jailor made him walk and told him that when the feeling of numbness starting in the legs reached his head he would die.”

Within 24 hours he was rushed to face the surgeon’s knife for emergency brain surgery. He lost the ability to speak during the crisis and became desperately concerned about the state of his mental faculties—his whole career rested on the delicate machinery of his grey matter. Nevertheless, during his convalescence he made one of the most consequential intellectual breakthroughs of his life.

## A solitaire-y epiphany

During the following months as Ulam began to recover, his fears of permanent effects from the illness slowly lessened. He was further encouraged when a telegram arrived offering him a position back at Los Alamos, signed by physicists Robert Richtmyer and Nick Metropolis. Ulam recalls in his memoir *Adventures of a Mathematician*, “this offer to return to Los Alamos to work among physicists and live once again in the exhilarating climate of New Mexico was a great relief for me.”

Having returned to Los Alamos, he was nevertheless still experiencing bouts of fatigue. While playing solitaire to while away the time during rest, Ulam asked himself a straightforward question: what are the chances that a hand laid out with 52 cards will come out successfully? It is a deceptively challenging problem—there are around  $8 \times 10^{67}$  ways to sort a deck of cards (a number approaching the estimated number of atoms in the observable universe). He wondered if instead of applying pure combinatorial calculations, which would be monstrously difficult, he could simply lay out the cards one hundred times and count the number of successful plays. Implicit was the assumption that each play started with randomized conditions.

“This was already possible to envisage with the beginning of the new era of fast computers,” he said, “and I immediately thought of problems of neutron diffusion and other questions of mathematical physics.” Now that Ulam had returned to Los Alamos, this meant questions posed by the development of the hydrogen bomb.

## ENIAC: The dawning of digital computing

The “new era of fast computers” that Ulam was thinking of was led at the time by the ENIAC (Electronic Numerical Integrator And Computer), the world’s first programmable, electronic digital computer, completed in 1945 at the University of Pennsylvania. It was built during World War II to calculate ballistic trajectories at a rate 10 times faster than the differential analyzers then in use. (The differential analyzer was a mechanical analog computer that used a wheel-and-disc mechanism, built in 1927 by Manhattan Project administrator Vannevar Bush and worked on by his young student Claude Shannon in 1936; aspects of ENIAC’s design were modelled on the differential analyzer).

Although construction of ENIAC was not finished until after the war, its computational speed—more than 1,000 times faster than its closest electromechanical competitor—ensured it would be in demand for years. It was initially programmed by rewiring cables and setting switches on an enormous set of plugboard panels (Fig. 3), but in 1948 it was converted to be a stored-program machine. ENIAC ran in the new stored-program configuration for the remainder of its service life. By the end of its



**Figure 2.** *Left:* Nick Metropolis, one of the original 50 scientists recruited for the Manhattan Project and team leader who helped implement the Monte Carlo method. He became known for his design of the MANIAC series of computers in the 1950s. *Right:* Robert Richtmyer, Theoretical division leader 1945–48. Richtmyer made contributions to von Neumann's original code for applying the Monte Carlo method to the ENIAC computer.

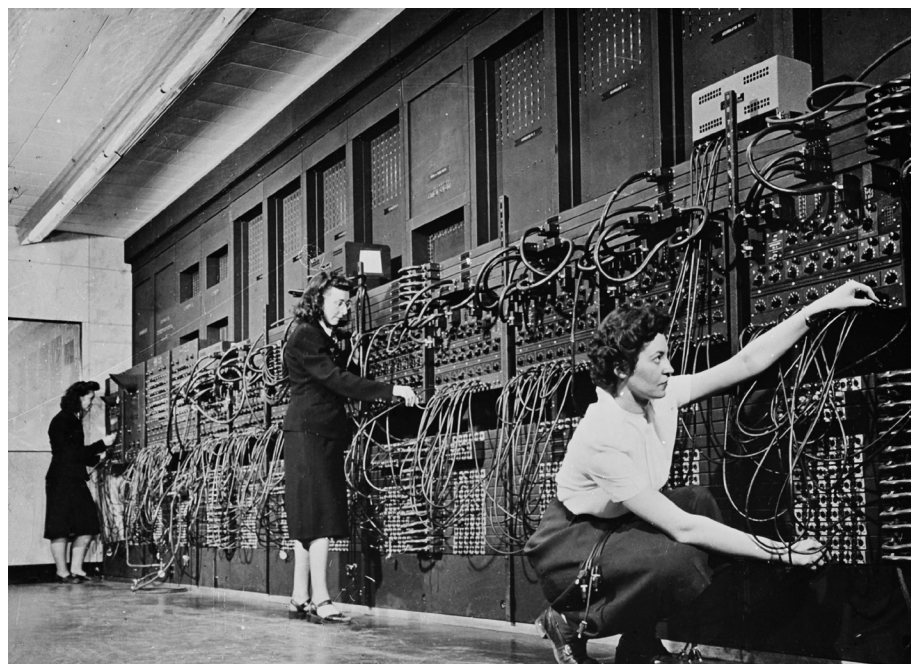

**Figure 3.** Marlyn Wescoff and Betty Jean Jennings configuring plugboards on the ENIAC (Electronic Numerical Integrator And Computer). The computer was developed as an Army ballistics project designed by John Mauchly and J. Presper Eckert, however, it was run by a team of women. The “ENIAC Six” included Kathleen McNulty, Mauchly's wife (her married surnames were Mauchly and Antonelli), Frances Bilas (Spence), Jean Jennings (Bartik), Ruth Lichterman (Teitelbaum), Marlyn Wescoff (Meltzer), and Betty Snyder (Holberton). For more information see [eniacprogrammers.org](http://eniacprogrammers.org) and the book *Proving Ground: The Untold Story of the Six Women Who Programmed the World's First Modern Computer* by Kathy Kleiman.



---

operation in 1956, it comprised a sprawling network of 18,000 vacuum tubes, 7,200 crystal diodes, 1,500 relays, 70,000 resistors, 10,000 capacitors, and approximately five million hand-soldered joints.

### **Von Neumann and the stored program paradigm**

The link between ENIAC and Los Alamos was John von Neumann, a brilliant mathematician and polymath—now recognized as one of the greatest minds of the twentieth century. Von Neumann had made pivotal contributions to the Manhattan Project, particularly to the implosion dynamics of the plutonium weapon, and was trying to conceive of a better way to perform the exponentially complex equations associated with rapid nuclear processes. Even before the war ended, he wrote to a colleague, “I am thinking about something much more important than bombs; I am thinking about computers.”

Von Neumann’s involvement with ENIAC seems to have arisen by pure chance. In 1944, while at a railway station he started chatting with a stranger who turned out to be an engineer who worked on ENIAC. Prior to this chance meeting, von Neumann had not heard of the project. After the war, von Neumann became involved with the development of the hydrogen bomb while also working as a consultant for the Ballistic Research Laboratory—sponsor of ENIAC—and saw the potential in Ulam’s statistical approach, which they had discussed during “an especially long conversation in a government car” while driving from Los Alamos to Lamy in 1946.

Ulam and von Neumann were professional colleagues but also good friends and eventually became neighbors on Bathtub Row in Los Alamos. Mathematician Gian-Carlo Rota said that “Stan was probably the only close friend von Neumann ever had. A similar background and a common culture shock brought them together. They would spend hours on end gossiping and giggling, swapping Jewish jokes, and drifting in and out of mathematical talk.”

### **Rolling the dice with Monte Carlo**

In 1947, von Neumann wrote a letter to Robert Richtmyer (Los Alamos Theoretical division leader) that contained the first formulation of a Monte Carlo computation for an electronic computer, a concept that was years ahead of its time. Shortly after, fellow colleague on the project Nick Metropolis coined the name for the method from its probabilistic nature. The name also referred to Ulam’s Polish uncle who would borrow money from relatives because he “just had to go to Monte Carlo” (the Las Vegas of Europe). The code was finalized later that year with input from Richtmyer, and the first calculations were run on ENIAC in April–May, 1948 for the computer’s first trial after it was upgraded to a stored-program machine.

Coincidentally, von Neumann had first met his wife Klára in Monte Carlo in 1936. Klára contributed significantly to the coding efforts of the Monte Carlo method, accompanying Metropolis to Maryland where they worked on ENIAC for 32 days without a break to modify the machine. “The method is clearly a 100% success,” von Neumann wrote at the time.

Von Neumann’s historical calculations were the first-ever programs written in the modern stored-program paradigm to be run on an electronic computer. Using his method, it was no longer necessary to physically unplug and reconnect wires every time a problem was changed. Ulam explained that “it was his feeling for and knowledge of the details of mathematical logic systems and the theoretical structure of formal systems that enabled him to conceive of flexible programming. This was

his great achievement.” This work had its immediate precursors in the work of Alan Turing and Konrad Zuse, among others, as well as collaborative work von Neumann had participated in with the design of EDVAC (Electronic Discrete Variable Automatic Computer), the successor to ENIAC based on the stored-program design that would become operational a few years later.

Laboratory historian Nic Lewis says that von Neumann’s work on EDVAC laid pivotal groundwork for development of the stored program paradigm: “Von Neumann’s major contribution, it seems, was his remarkable ability to translate the EDVAC collaboration’s work around a specific architecture into a generalizable, logical representation that others could emulate, without having to copy the EDVAC design.”

Ulam later remarked, “It is still an unending source of surprise for me to see how a few scribbles on a blackboard or on a sheet of paper could change the course of human affairs.” The calculations remained classified until the late 1950s, however, the method itself was not. Ulam was quick to promote the idea on a national lecture tour before it had even been published, helping it spread beyond the Laboratory. It found rapid success in the fields of physics, physical chemistry, and operations research.

**FERMIAC and the insomniac**

Remarkably, the ingenious physicist Enrico Fermi independently invented the fundamentals of Ulam’s random sampling method back in the 1930s while studying neutron moderation in Italy, but he had chosen to keep this part of his work secret and unpublished. Indeed, his colleagues often wondered how Fermi arrived at his answers so much faster than they did. Fermi was an insomniac who was always calculating equations with his pocket slide rule. This habit of Fermi’s prompted Robert Oppenheimer to quip, “He was simply unable to let things be foggy. Since they always are, this kept him pretty active.”

During a short hiatus in the ENIAC operation as it was moved between locations, Fermi dreamt up an analogue device to continue studies into neutron transport. At the time, this device was known as the Monte Carlo Trolley, but it was renamed the FERMIAC when Los Alamos scientists rediscovered it after Fermi’s death in the 1960s. Built as a brass and acrylic device by colleague L.D.P. “Perc” King in 1947, it employed a series of rotating drums that moved a stylus over a sheet of paper (Fig. 9). The action of the drums was dictated by a Monte Carlo process with pseudorandom numbers, giving a two-dimensional drawing of the resultant neutron genealogies. It was used by Fermi for approximately two years and remains a curiosity from this era of computing.

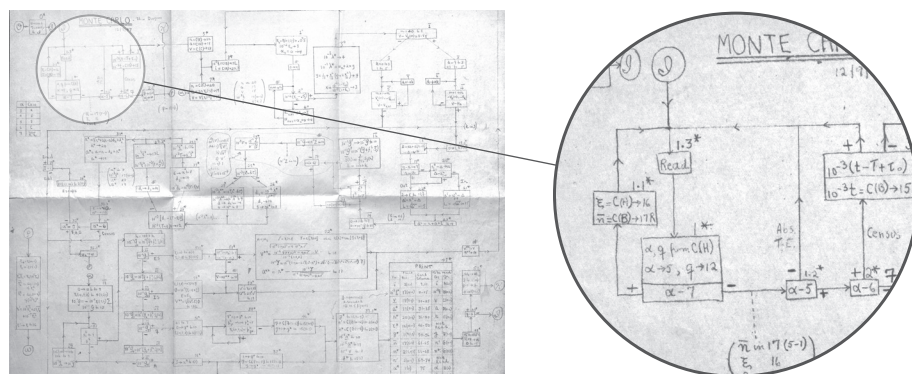

Figure 4. Von Neumann's 1947 Monte Carlo programming flow chart for ENIAC.



**Figure 5.** Stanislaw Ulam claiming his winnings in a game of poker; Nick Metropolis visible on lower-right edge of photo. From Ulam's memoir: "One thing that relieved the repetition and alternation of work... was when a group of us would play poker once a week... We played for small stakes; the naivete of the game and the frivolous discussions laced with earthy exclamations and rough language provided a bath of refreshing foolishness from the very serious and important business that was the *raison d'être* of Los Alamos... Metropolis once described what a triumph it was to win ten dollars from John von Neumann, author of a famous treatise on game theory. He then bought his book for five dollars and pasted the other five inside the cover as a symbol of victory."



**Figure 6.** John von Neumann, Claire Ulam, and Stanislaw Ulam in the Ulam backyard on Bathtub Row in Los Alamos, circa 1954. The von Neumanns were next-door neighbors to the Ulams for many years.





**Figure 7.** Pinocchio was a “puppet” reactor that used ping-pong balls to simulate nuclear fission, photographed here at the LASL museum in 1966. It demonstrates the types of trajectories that Ulam and von Neumann sought to simulate using the Monte Carlo method. Also known as the popcorn machine, Pinocchio was a star exhibit at the museum. It has recently been reengineered—you can see Pinocchio 2.0 at the Bradbury Museum, along with a forthcoming exhibit on the Monte Carlo method due in 2024.

*Further reading:*

1. “From Cardinals to Chaos: Reflections on the Life and Legacy of Stanislaw Ulam,” *Los Alamos Science*, 15, 1987.
2. S.M. Ulam, “Adventures of a Mathematician,” Scribner’s, New York, 1976.
3. N. Lewis, W. Spivey, “Computing on the mesa,” *National Security Science*, Winter 2020.
4. A. Sood, R.A. Forster, B.J. Archer, R.C. Little “Neutronics Calculation Advances at Los Alamos: Manhattan Project to Monte Carlo,” *Nucl. Technol.*, 2021, 207:sup1, S100-S133.
5. K. Kleiman, “Proving Ground: The Untold Story of the Six Women Who Programmed the World’s First Modern Computer,” *Grand Central Publishing*, New York, 2022.

Statistical sampling methods had been around for a long time. For instance, Buffon’s needle problem dates from the eighteenth century and uses a similar concept to the Monte Carlo method. Nevertheless, it was Ulam’s idea to combine statistical sampling methods with the emerging computing technology of the time that ensured the success of the method—a simple concept that can solve complex problems.

**The seeds of the future**

The enormous impact of the Monte Carlo method can be thought of itself as a genealogical network of influences, all leading back to Ulam’s epiphany and his friendship with von Neumann. Along with the Monte Carlo method, many other great advances in applied mathematics arose from their conversations, such as cellular automata, stimulated growth patterns, and other pioneering computer-based mathematical experiments.

As Ulam says in his memoir, “Little did we know in 1946 that computing would become a fifty-billion-dollar industry annually by 1970.” Von Neumann died in 1957 and did not see the true blossoming of his life’s work. “Too bad he did not live to see how computers have revolutionized everything and what influence they will have on science in general and even on pure mathematics,” Ulam said. “His role in their development was tremendous.” Ulam, a man of great understatement, added, “If I may say so... I too played a modest role in showing how to use computers!”

**Acknowledgments**

Many thanks to Nic Lewis, Jill Gibson, Avneet Sood, Joel Kulesza, Linda Deck, and Omar Juveland for their assistance in writing this article.

## How does the Monte Carlo method work?

The underlying concept behind the Monte Carlo method uses randomness to solve problems that might still be deterministic in principle, a significantly different approach to trying to use differential equations. Consider a straightforward statistical problem, for how to determine the average height of a large group of people. It follows that a random sampling method would help make an unbiased, representative selection of inputs. As more and more people are sampled, confidence in the statistical average increases (known as the law of large numbers). Thus, it is not necessary to sample every single person in the group to gain a useful answer.

This is the same fundamental process that is used to trace neutron movements through fissionable materials—the original goal of the method as developed at Los Alamos in the 1940s. In a simulation of a fission chain reaction, the path of each neutron starting from  $t = 0$  is estimated based on geometric and other physical factors. When the neutron path collides with an atomic nucleus in the material, a choice must be made as to where and how it could scatter. In principle, the neutron could be scattered 360 degrees in any direction:  $4\pi$  steradians. Although this is a deterministic process in the actual material, the Monte Carlo method uses randomness to dictate the angle of scattering as well as other factors. This type of chain is called a Markov chain or Markov process, a stochastic process, which is not reliant on its history. This is repeated thousands of times until a vast network (a three-dimensional “genealogy”) of statistical outcomes emerges that converges asymptotically to the true solution. The final output gives the likelihood of a range of results occurring—because it is a statistical method, the answers are never exact and are always accompanied by a calculable degree of uncertainty.

The Monte Carlo method is not just useful for calculating neutron paths—it represents a class of algorithms that can be applied to a large range of problems. The method is so useful because it only requires a range of estimated values as inputs rather than a set of fixed values. This versatility allows it to tolerate large numbers of random variables, which would not be feasible using many other approaches. Other advantages of the Monte Carlo method include the ability to conduct sensitivity analysis, allowing decision-makers to see the impact of individual inputs on a given outcome. It also allows correlations of inputs to be calculated, which enables users to understand relationships between input variables. Monte Carlo simulations are used today in a huge number of disparate applications, such as calculating light paths in three-dimensional rendering of digital images, simulating profits or losses in online trading of stocks, designing experiments in chemical and engineering applications, and teaching AI systems to play complex board games such as Go.

### Monte Carlo N-Particle® applications

Monte Carlo N-Particle (MCNP®) software is used at Los Alamos for a variety of modeling applications. In the name, which Triad National Security, LLC has recently trademarked, “N-Particle” refers to the large variety of particles (neutrons, photons, electrons, etc.) that can be simulated. The many applications of the Los Alamos MCNP® code include the following: radiation physics, nuclear criticality safety and experiment design, nuclear oil-well logging, fission and fusion reactor design, decontamination and decommissioning, nuclear safeguards, and nonproliferation. At the Laboratory, the Monte Carlo Codes group (XCP-3), part of X Computational Physics, specializes in developing modern Monte Carlo codes.

Visit [mcnp.lanl.gov](http://mcnp.lanl.gov) for more information.

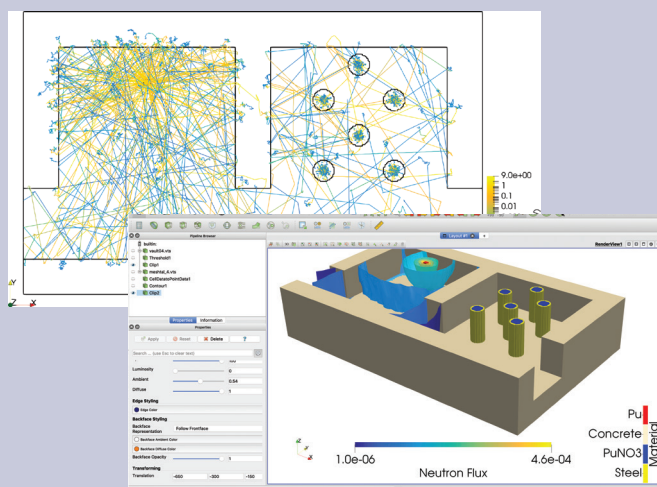

**Figure 8.** These images show a fissile material vault with two rooms, one with a small plutonium sphere and one with metal tanks containing plutonium nitrate liquid. The lines drawn show neutrons traveling from these two radioactive regions and interacting with the environment, as simulated by the MCNP code. Because the sphere is more radioactive than the liquid, more neutrons start in the left-hand room and travel further rather than being trapped in the liquid within the tank walls. The 3D perspective view was generated using ParaView software, with neutron-flux isocontour surfaces emanating from the plutonium sphere. If the plutonium nitrate liquid were more radioactive, we would also see flux isocontour surfaces near those tanks. Credit for images and figure caption: Joel Kulesza (XCP-3).



# The FERMIAC

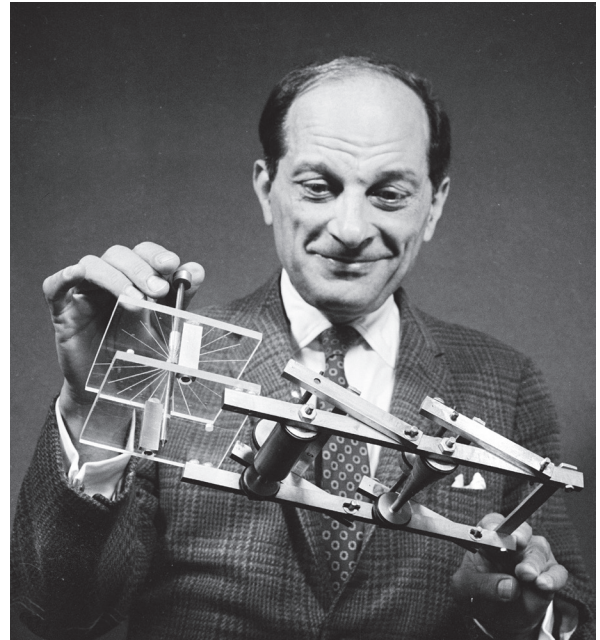
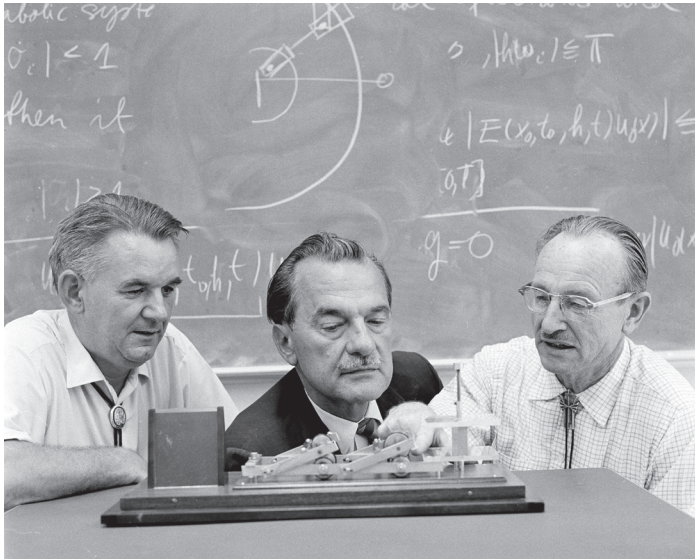

**Figure 9.** Left: Bengt Carlson, Nick Metropolis, and Perc King, 1966; Right: Stanislaw Ulam with the FERMIAC, 1966.

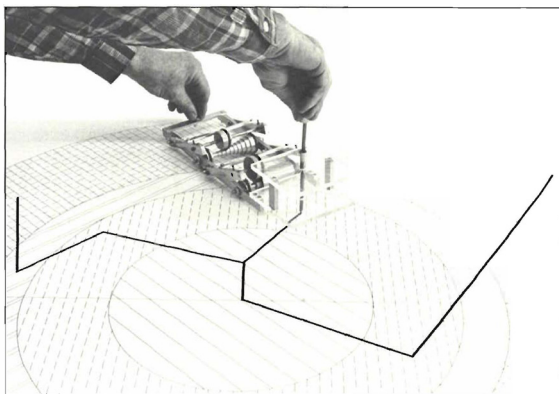
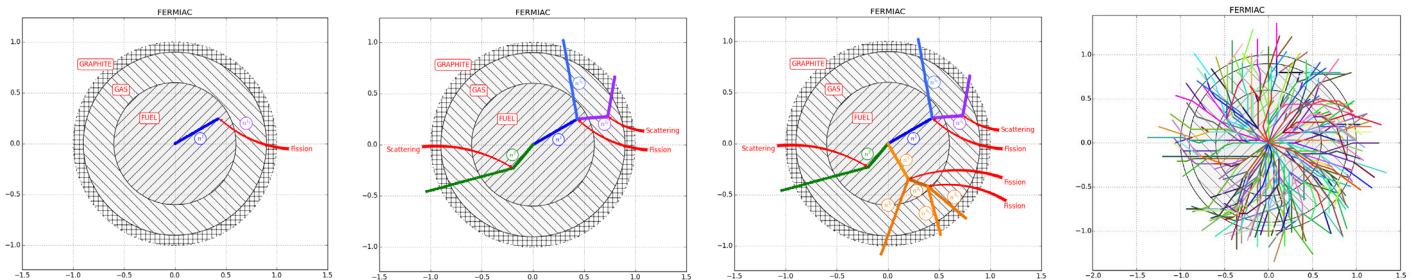

**Figure 10.** A replica of the Fermiac was built at Istituto Nazionale di Fisica Nucleare (INFN) Torino, Italy mechanical workshops of Bologna in 2015, on behalf of the Museo Storico della Fisica e Centro Studi e Ricerche “Enrico Fermi”, thanks to the original drawings made available by Los Alamos National Laboratory. This reproduction of the Fermiac was put in use, and a simulation was developed.

An example of the Fermiac used to follow the fate of the genealogy of source neutrons  $n_1, n_2, n_3$  in a cell of a nuclear reactor.

Courtesy: F. Coccetti, “The Fermiac or Fermi’s Trolley,” *Il Nuovo Cimento* 39 C, 2016, 296.





THE GLENN T.  
SEABORG  
INSTITUTE

**Actinide Research Quarterly** is published by Los Alamos National Laboratory and is a publication of the Glenn T. Seaborg Institute for Transactinium Science, a part of the National Security Education Center. ARQ (est. 1994) highlights research in actinide science in such areas as process chemistry, metallurgy, surface and separation sciences, atomic and molecular sciences, actinide ceramics and nuclear fuels, characterization, spectroscopy, analysis, and manufacturing technologies.

LA-UR 23-30416

**Address correspondence to:**

*Actinide Research Quarterly*  
c/o Editor  
Mail Stop T-001  
Los Alamos National Laboratory  
Los Alamos, NM 87545

**ARQ can be read online at:**

[www.lanl.gov/arq](http://www.lanl.gov/arq)

**If you have questions, comments, suggestions,  
or contributions, please contact the ARQ staff at:**  
[arq@lanl.gov](mailto:arq@lanl.gov)

*National Security Education Center*  
David L. Clark, Director

*G. T. Seaborg Institute for Transactinium Science*  
Science Advisors  
Franz Freibert, Director  
Ping Yang, Deputy Director

*Editor*  
Owen Summerscales

*Designers/Illustrators*  
Sarah Tasseff  
Owen Summerscales  
Brenda Fleming

---

Los Alamos National Laboratory is operated by Triad National Security, LLC, for the National Nuclear Security Administration of U.S. Department of Energy (Contract No. 89233218CNA000001).

This publication was prepared as an account of work sponsored by an agency of the U.S. Government. Neither Triad National Security, LLC, the U.S. Government nor any agency thereof, nor any of their employees make any warranty, express or implied, or assume any legal liability or responsibility for the accuracy, completeness, or usefulness of any information, apparatus, product, or process disclosed, or represent that its use would not infringe privately owned rights. Reference herein to any specific commercial product, process, or service by trade name, trademark, manufacturer, or otherwise does not necessarily constitute or imply its endorsement, recommendation, or favoring by Triad National Security, LLC, the U.S. Government, or any agency thereof. The views and opinions of authors expressed herein do not necessarily state or reflect those of Triad National Security, LLC, the U.S. Government, or any agency thereof. Los Alamos National Laboratory strongly supports academic freedom and a researcher's right to publish; as an institution, however, the Laboratory does not endorse the viewpoint of a publication or guarantee its technical correctness.

# Actinide Research Quarterly

Mail Stop T001  
Los Alamos National Laboratory  
Los Alamos, NM 87545

[arq@lanl.gov](mailto:arq@lanl.gov)

Presorted Standard  
U.S. Postage Paid  
Albuquerque, NM  
Permit No. 532

